

## MX 62

Monitoring system for gas and flame detection

- Back up processor to ensure continual measurement (SIL 3 from EN 50402)
- 64 secure channels
- Modularity and flexibility
- Reduced installation costs
- Direct connections either on network or in loops

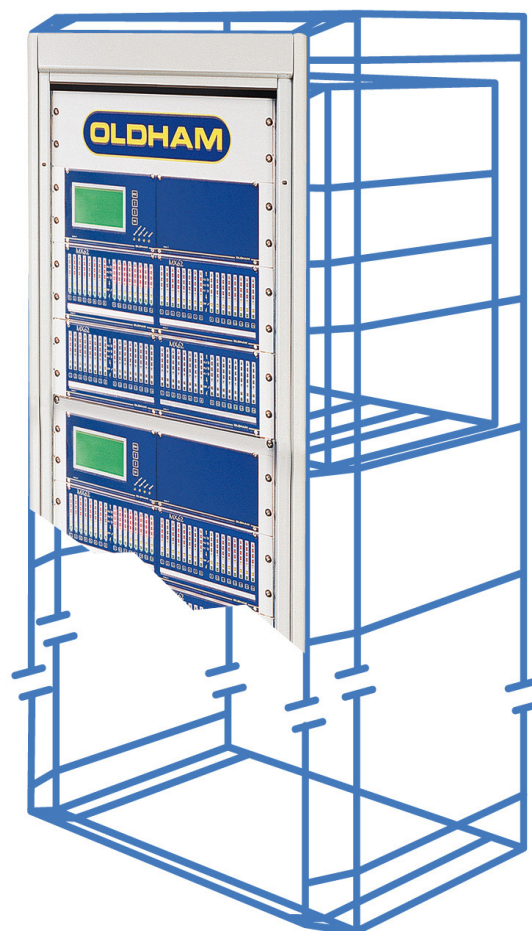

### Certifications

**ATEX**



**CE**

## A secure system for gas and flame detection

The MX 62 provides a back up system, to ensure an accurate analysis from the sensors to meet more and more specific requirements. The MX 62 system already meets the requirements of ATEX 100 A and offers the high level of security required by the SIL 3 (EN 50402).

The MX 62 monitor has incorporated these new requirements and other future needs. Through its modularity, flexibility, installation and reduced operational costs, the MX 62 is a very attractive solution.

## A secure installation for optimized costs

### An entirely secure installation

The structure of the MX 62 system has been developed to provide dual measurement: reliable data is passed quickly from the detectors to the relays.

### A structured programming

The ConfigPro.Exe software configures the MX 62 via a PC.

Access to the different functions is protected by several passwords.

### Space saving and easy access to the different element of the MX 62

### An optimized cost

The performance is innovative and meet the new requirements in terms of security

- The modularity allows a personalized operation and reduces wiring costs
- The flexibility helps integration of your system
- The reliability ensures minimum maintenance
- Programming the outputs considerably reduces the relay requirements



Exemple d'installation 256 capteurs

Operating panel

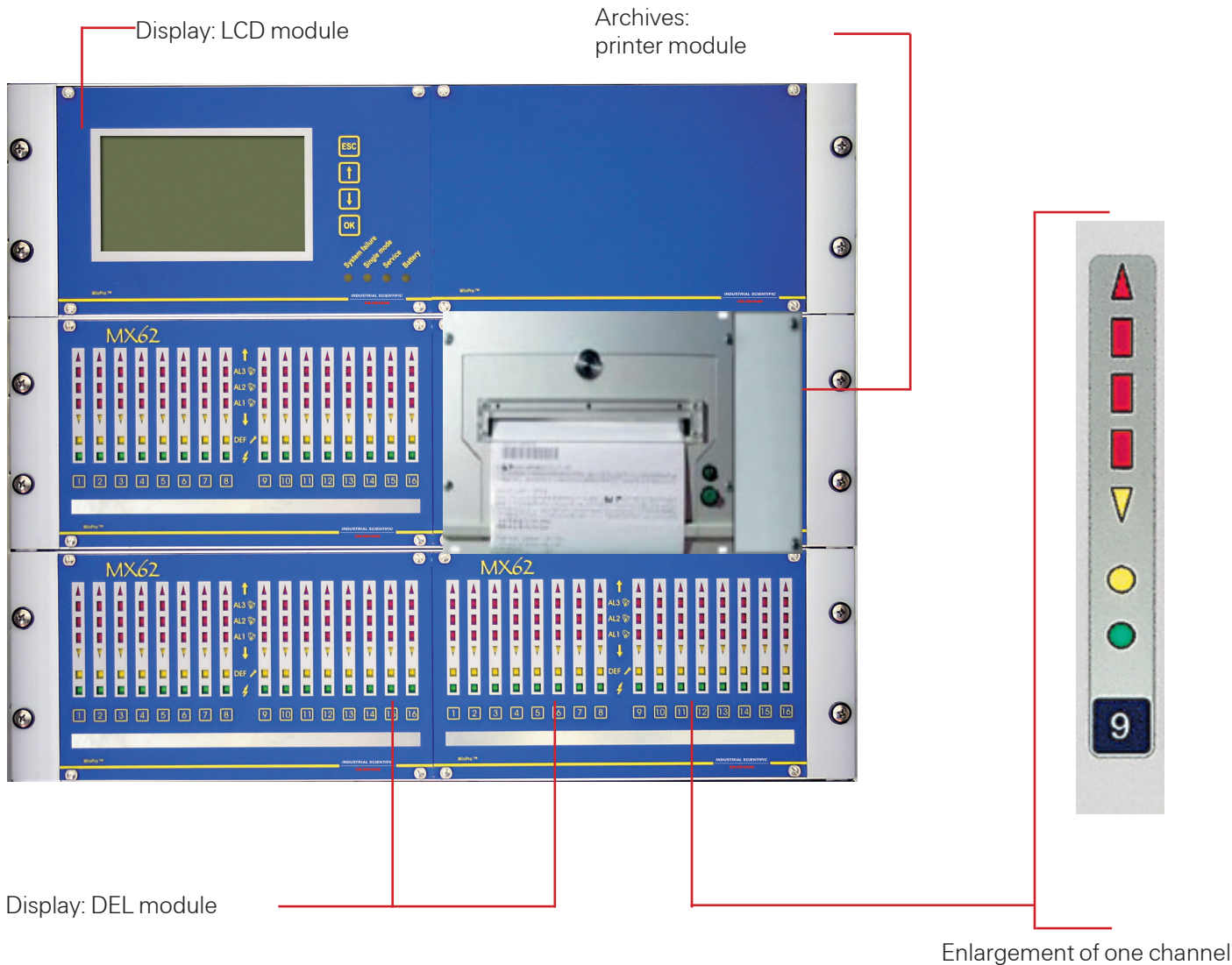

Supervisor

- Synoptic display
- Display of measurements and operating status of the detectors
- Display of curves and historic charts with a printout
- Communication through the internet

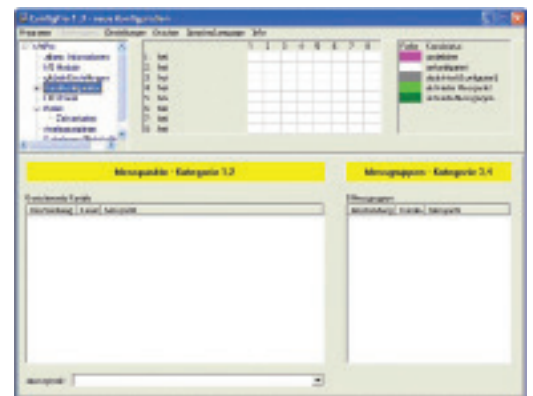

Supervisor

Example of an installation with an MX 62 monitor

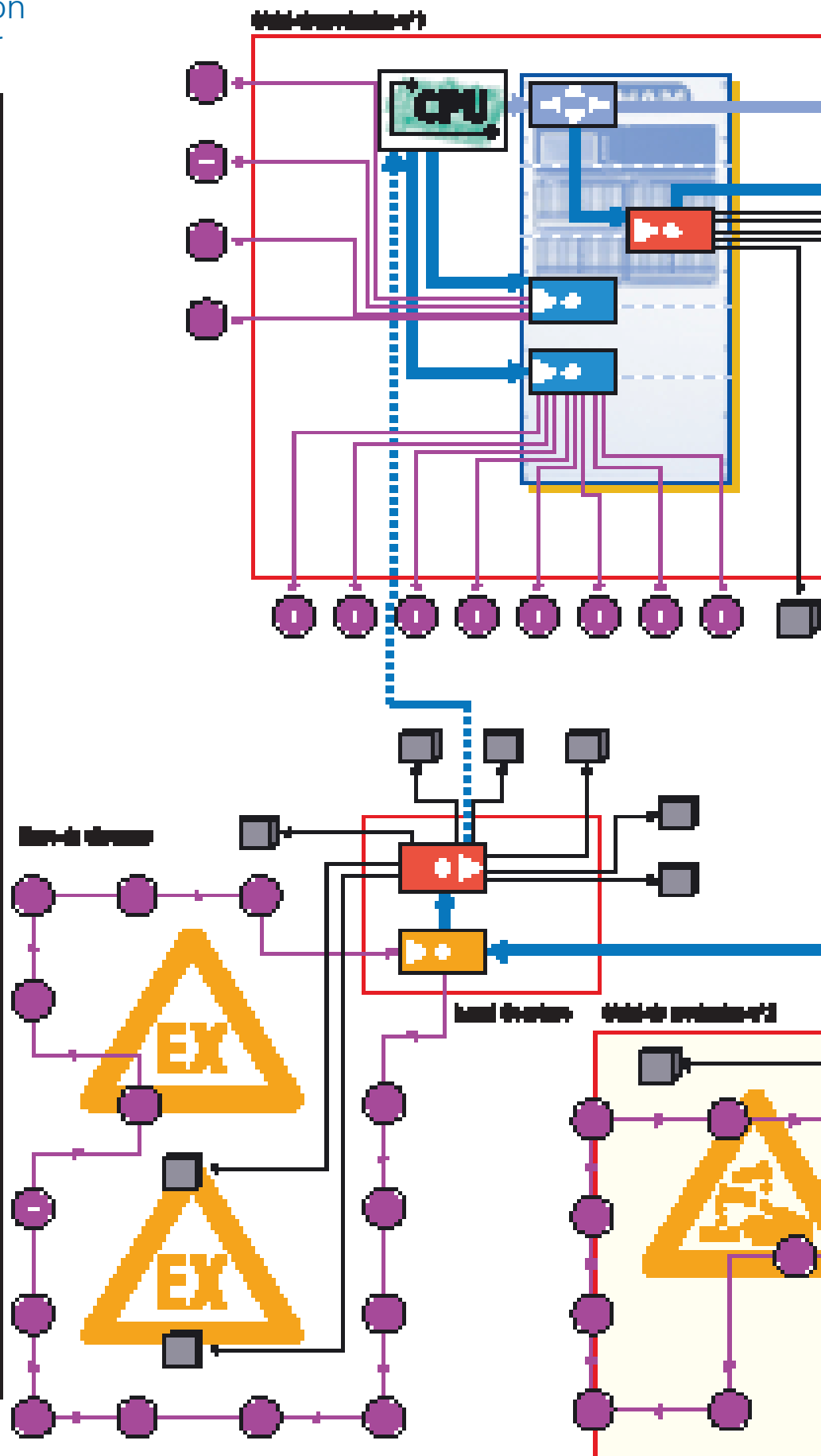

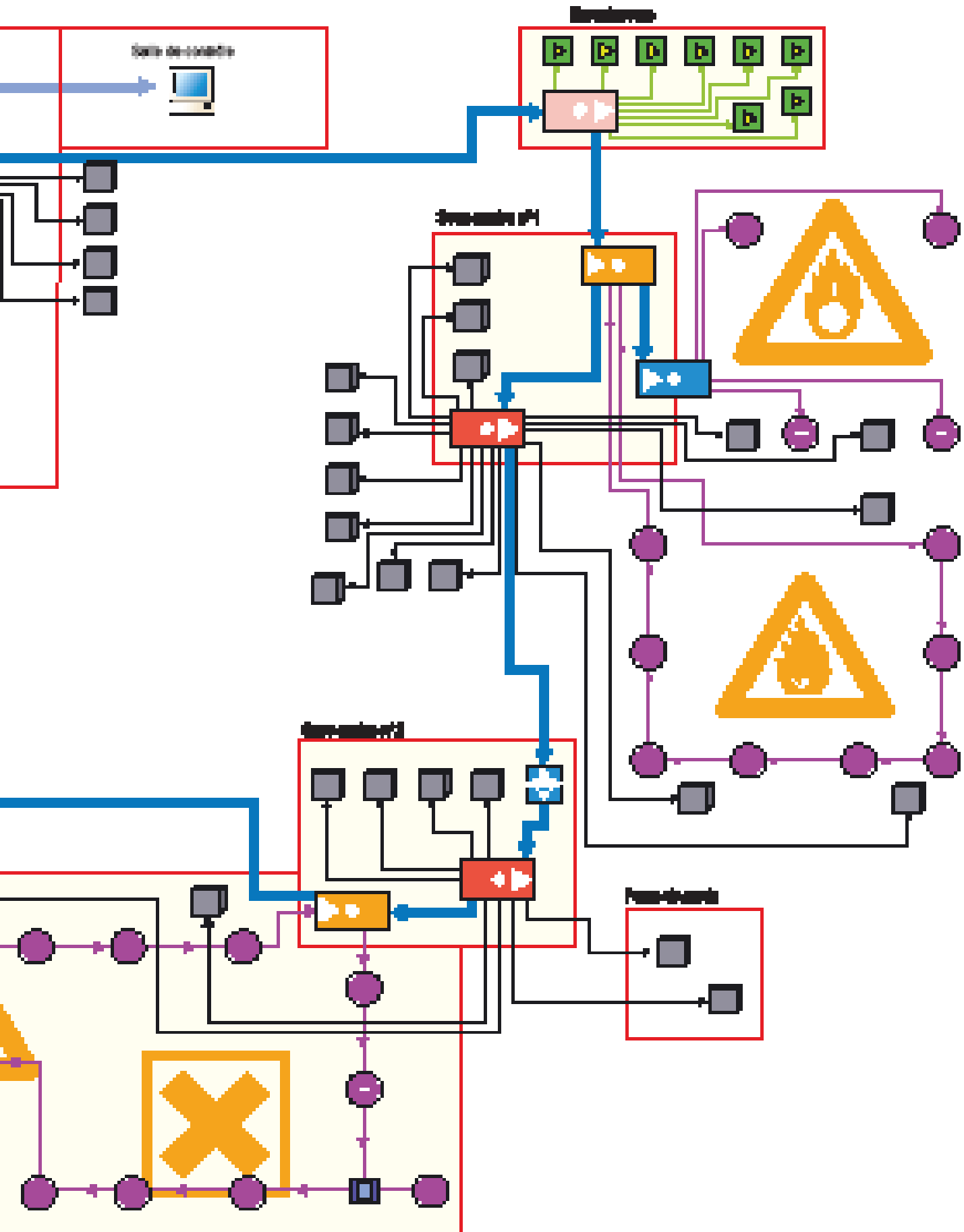

## Various modules

### CPU module

The CPU module is the heart of the system. Its back up power supply and its two processors secure the MX 62 management.

Plug in the DEL and LCD modules, or remote connection with the RS485 connection (4 wires + screened system).

- Centralised management
- Connection to different modules
- Connection to an internal or external printer
- Dimensions: 240 x 130 x 50 mm (chassis not included)
- Consumption: 12 W
- Nominal tension: 24 VCC
- Minimal tension: 19.2 VCC



### DEL module

16 channels available although the electronic equipment is designed for 8 channels as standard.

- 4 alarm thresholds
- Zero checking (reset)
- Power "on"
- Disturbance
- Dimensions: 3U x 1/2 19" x 30mm (chassis not included)
- Consumption: 4W for 8 channels
- Nominal tension: 24 VCC
- Minimal tension: 19.2 VCC

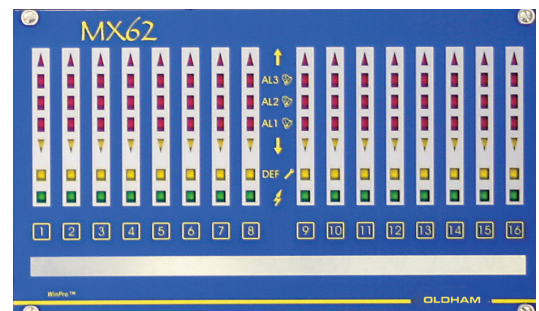

### LCD module

- Graphic, alphanumeric, LCD high definition
- User-friendly
- Data storage: at least 5 days or more (option)
- Can be remote via the RS 485 (4 wires + screened system)
- Dimensions: 3U x 1/2 19" x 40 mm (chassis not included)
- Consumption: 8 W
- Nominal tension: 24 VCC
- Minimal tension: 19.2 VCC

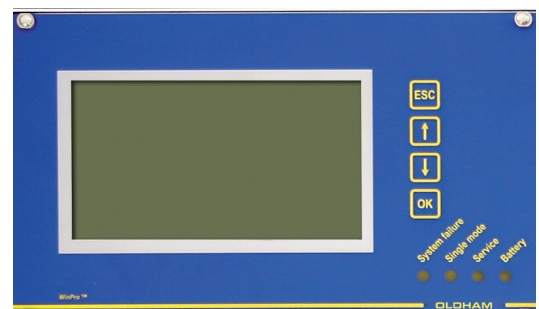

Up to 29 displays can be networked with the MX 62, allowing measurement indication wherever you require them.

### Printer module

- Printing of results, relay operating status, fault, min/max average over 8 hours
- Type ASCII, alphanumeric 40 or 80 characters
- Parallel connection
- Dimensions: 34 x 1/2 19" x 75 mm thermal paper width : 110 mm
- Consumption: 18 W
- Nominal tension: 24 VCC
- Minimal tension: 21.5 VCC
- Tension mini : 21,5 VCC



## Analogue input module

This module allows the analogue detectors to network; It transmits the information back to the CPU via 2 different analogue/digital convertors.

- Direct connection with the MX 62 system or removed via the adapter module
- Up to 8 measurements points
- DIN rail mounted
- Dimensions: 160 x 90 x 70 mm
- Consumption: 1 W



## Adapter module

It allows 3 operating modes:

- Up to 16 addressable detector loop
- Up to 8 addressable detector loop combined with a remote analogue module
- Connection of 2 analogue input modules
- Dimensions: 195 x 90 x 100 mm
- Consumption: 10 W
- Nominal tension: 24 VCC
- Minimal tension: 19.2 VCC

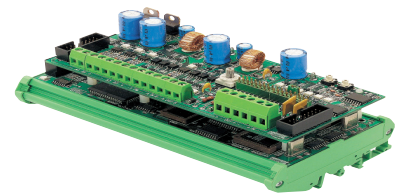

The module can be remote via 2 networks RS485 (2 x 4 wires + screened system)

## Relay module

It is fitted with 2 processors linked with the CPU

- Principal module: 8 relays
- Extension module: 8 relays
- NO/NC contacts
- Breaking capacity: 460 VA, 60 W
- Positive safety individually programmable
- Principal module dimension: 195 x 90 x 55 mm
- Principal module dimension extended with 16 relays : 195 x 90 x 90 mm
- Maxi consumption: 15 W
- Minimal tension: 20.5 VCC

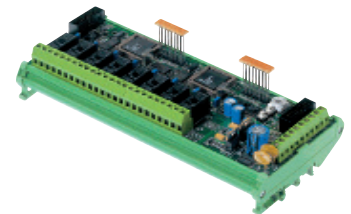

The module can be remote via 2 RS485 (2 x 4 wires + screened system)

## Analogue output module

It is fitted with 2 processors linked with the CPU

- Fitted with 8 analogue 4-20 mA or 0-10 V outputs

Each output is programmed to transmit:

- The growth value for one detector
- The linearized value
- Means or max for a detectors group
- Dimensions: 160 x 90 x 70 mm
- Consumption: 8 W
- Nominal tension: 24 VCC
- Minimal tension: 19.2 VCC
- New modules pending (mid 2005):
- Open collector (56) suitable to drive LED mimic panel as per MX 62 channels
- Communication splitter module providing 3xRS232 ports for remote data exportation

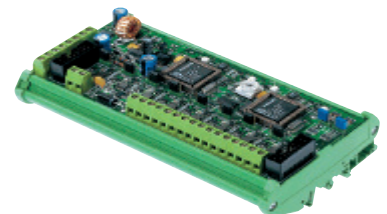

## Communication module

It ensures the link towards a supervisor and a modem.

- Link with CPU via the RS 232
- Personalized or modbus protocol via RS 422
- Dimensions and consumption: consult us.

NB : DEL and LCD modules use a common RS 485.

The adapters modules, relays and analogue outputs share two other RS 485.

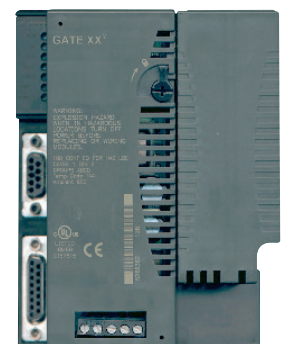

## Caractéristiques techniques

MX 62	
Capacity	64 secure channels per system ( 128 channels per console)
Casing	Electric opening, box and console
Display	High definition graphic alphanumeric LCD, remote and optional
Programming	Various possibilities : voting, boolean calculations, Increasing and decreasing alarms, mean etc
ALARMS	
Visual alarms	Gas : 4 thresholds  Maintenance: - Calibration mode - Fault - Zero checking  Power "on"
Audible alarms	Via specialised relays
Inputs	4-20 mA Numeric
Outputs	4-20 mA Numeric Relays (128 max.)
Printer	Centronix connection
Power supply	24 V DC , 230 VAC (others on demand) Alimentation securue
Operating temperature	-15°C to +50°C
Rack dimensions	H from 3U x L 19" x P 120 mm
Standards	CE, SIL3 of EN 50402 and BSV 03 ATEXG002X
Others	Programming software Supervision software

As an ISO 9001 & ISO 14001 approved company, OLDHAM quality assurance programmes demand the continuous assessment and improvement of all OLDHAM products. Information in this leaflet could thus change without notification and does not constitute a product specification. Please contact OLDHAM or their representative if you require more details.

**EMEAI  
Arras- France**  
ZI Est, Rue Orfila, CS 20417  
62027 ARRAS CEDEX  
France  
Tél : +33 (0) 3 21 60 80 80  
Fax : +33 (0) 3 21 60 80 00  
info@oldhamgas.com

**AMERICAS  
Texas - USA**  
4055 Technology Forest Blvd.  
The Woodlands, Texas 77381  
USA  
Tel : +1 800 247 7257  
Fax : +1 704 291 8330  
sh-sale@tycoint.com

**ASIA PACIFIC  
Shanghai-China**  
290 Guiqiao Road  
Pudong, Shanghai 201206  
People's Republic of China  
Tél : +86 21 3127 6373  
Fax : +86 21 3127 6365  
sales@oldhamgas.com

