

Gas Detection System

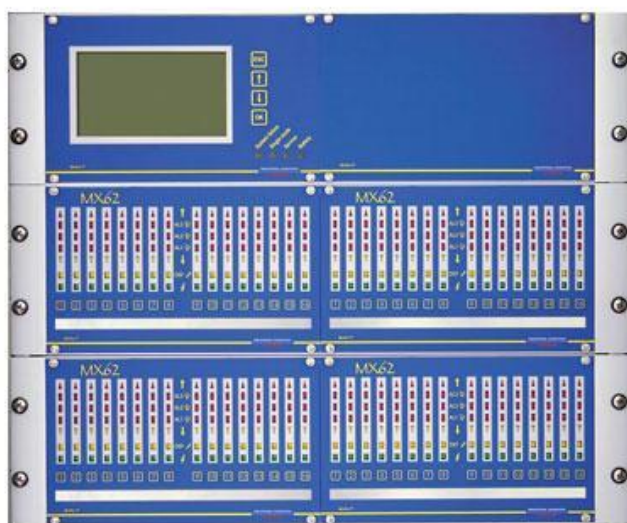

Part Number: NPM62GB
Version: G.0

Subject to change without notice

FE BA WinPro MX 62 R6 GB 1604CBR

Dear Customer!

The purchase of the system WinPro[®] / MX62 reflects your responsibility towards human life and the environment. The gas detection systems of *OLDHAM* are tested and used by satisfied customers worldwide within the industry and commerce as well as at public facilities and private homes. Wherever combustible gases, toxic gases and oxygen are to be monitored, *OLDHAM* is a reliable partner for the matters of safety engineering.

This operation manual describes the functionality and maintenance of as well as the scope of possible connections to the gas detection system WinPro[®] / MX62 for easy handling and adaptation to your requirements and purposes.

Besides the system WinPro[®] / MX62 described herein, detectors are required for gas monitoring, converting the gas concentration into an electric signal. Operation and service of various detectors are detailed separately.

The gas detection systems of *OLDHAM* are state-of-the-art and in view of improvements, technical specifications are consequently subject to change without notice.

Should you have any further questions or encounter problems during employment, please do not hesitate to contact us.

Arras, April 2016

Oldham S.A.S.
Rue Orfila
Z.I. Est – CS 20417
F – 62027 ARRAS Cedex
Tel: +33 (0)3 21 60 80 80
Fax: +33 (0)3 21 60 80 00
Internet: www.oldhamgas.com
E-mail: info@oldhamgas.com



Thank you for choosing this OLDHAM instrument. All of the necessary actions have been taken in order to ensure your complete satisfaction with this equipment. It is important that you read this entire manual carefully and thoroughly.

THE EXTENT OF OUR RESPONSIBILITY

OLDHAM shall not be held responsible for any damage to the equipment or for any physical injury or death resulting in whole or in part from the inappropriate use, installation, or storage of the equipment, which is the result of not complying with the instructions and warnings, and/or with the standards and regulations in force.

OLDHAM does not support or authorise any business, person, or legal entity in assuming responsibility on behalf of OLDHAM, even though they may be involved in the sale of OLDHAM products.

OLDHAM shall not be responsible for any damage, direct or indirect, or for damages and interest, direct or indirect, resulting from the sale and use of any of its products UNLESS SUCH PRODUCTS HAVE BEEN DEFINED AND CHOSEN BY OLDHAM FOR THE USE THAT THEY ARE INTENDED.

OWNERSHIP CLAUSES

The drawings, specifications, and information herein contain confidential information that is the property of OLDHAM.

This information shall not, either in whole or in part, by physical, electronic, or any other means whatsoever, be reproduced, copied, divulged, translated, or used as the basis for the manufacture or sale of OLDHAM equipment, or for any other reason without the prior consent of OLDHAM.

WARNING

This is not a contractual document. In the best interest of its customers and with the aim of improving performance, OLDHAM reserves the right to alter the technical features of its equipment without prior notice.

READ THESE INSTRUCTIONS CAREFULLY BEFORE THE FIRST USAGE: these instructions should be read by all persons who have or will have responsibility for the use, maintenance, or repair of the instrument.

This instrument shall only be deemed to be in conformance with the published performance if used, maintained, and repaired in accordance with the instructions of OLDHAM by OLDHAM personnel or by personnel authorised by OLDHAM.

GUARANTEE

Under normal conditions of use and on return to the factory, parts and workmanship are guaranteed for 2 years, excluding such consumables as sensors, filters, etc.

Destruction of the equipment



European Union (and EEA) only. This symbol indicates that, in conformity with directive DEEE (2002/96/CE) and according to local regulations, this product may not be discarded together with household waste.

It must be disposed of in a collection area that is set aside for this purpose, for example at a site that is officially designated for the recycling of electrical and electronic equipment (EEE) or a point of exchange for authorized products in the event of the acquisition of a new product of the same type as before.

contents

1. PRESENTATION	11
2. SYSTEM CONFIGURATION	11
2.1. Description of Modules	12
2.1.1. Controller module (CM)	12
2.1.2. Analog input module (AEM).....	12
2.1.3. LED Module	13
2.1.4. Basic relay (RBM) and Extension relay module (REM)	13
2.1.5. Loop module (LOOPM)	14
2.1.6. Analog output module (AAM)	15
2.1.7. LCD module	15
2.1.8. Logo module	15
2.1.9. Analog input extension module (AEAM).....	16
2.1.10. LCD copy module	16
2.1.11. MIMIC Module.....	16
2.2. Redundancy of WinPro / MX62	17
2.3. Control Pane of WinPro / MX62	17
3. OPERATION OF THE SYSTEM WINPRO / MX62	19
3.1. Channel and System Information.....	19
3.1.1. ISA procedure (slow flashing channel LED)	20
3.1.2. General buzzer relay	20
3.2. Sytem start-up	21
3.3. Normal Operation.....	21
3.3.1. Operating status.....	22
3.3.2. Alarms.....	22
3.3.3. Channel fault	22
3.3.4. Negative measured values	23
3.3.5. Under scale (US)	23
3.3.6. Over scale (OS)	24
3.3.7. Resetting of Alarm Signals.....	25
3.4. Service Mode	26
3.4.1. Alarm suspension (switch position 1).....	26
3.4.2. Operational test (switch position 2).....	27
3.4.3. Calibration (switch position 3).....	27
3.4.4. Channel on/off (switch position 4).....	27
3.4.5. PC communication (switch position 5).....	28
3.4.6. Ignore communication fault with relay modules (switch position 6).....	29
3.4.7. General alarm suspension	30
3.5. Single mode.....	30
3.6. System failure.....	31
3.7. Measures against Faults	32
3.8. Error Codes of the CM.....	34
3.9. Overview of LED indications	35

4.	OPERATION OF LCD MODULE	37
4.1.	Display of channels	37
4.2.	Menu	37
4.2.1.	System / LED-test.....	38
4.2.2.	System / System status	38
4.2.3.	System / System information.....	38
4.2.4.	Channel information / Actual information	38
4.2.5.	Channel information / Display of configuration	38
4.2.6.	Relays	38
4.2.7.	Analog outputs	39
4.2.8.	Datalogger / Set-up	39
4.2.9.	Datalogger / Histogram	39
4.2.10.	Datalogger / Events.....	39
4.2.11.	Datalogger / 8-hour mean values	40
4.2.12.	Datalogger / Format.....	40
4.2.13.	Printer settings	40
4.2.14.	LCD settings	40
5.	COMMISSIONING AND MAINTENANCE	43
5.1.	Calibration and adjustment	44
5.1.1.	Direct calibration at the detector	44
5.1.2.	Remote calibration for standard detectors	44
5.1.3.	Manual and automatic field adjustment of digital detectors	44
6.	TECHNICAL DATA.....	45
7.	CONNECTION AND CONFIGURATION OF THE MODULES	47
7.1.	Controller module (CM).....	47
7.2.	Analog input module (AEM).....	48
7.3.	Analog input extension module (AEAM).....	49
7.4.	Basic relay module (RBM) and extension relay module (REM)	50
7.5.	Loop module (LOOPM)	51
7.6.	Analog output module (AAM)	52
7.7.	LCD module / LCD copy module	53
7.8.	MIMIC Module.....	54
8.	CONNECTION AND INSTALLATION	55
8.1.	Wiring	55
8.1.1.	Mains supply	55
8.1.2.	Connection of relays	55
8.1.3.	Connection of detectors	55
8.2.	Installation of WinPro / MX62	56
8.2.1.	Wall-mounted housing	56
8.2.2.	19 inch rack	56
8.2.3.	Control panel.....	56

9.	CUT-OUT FOR CONTROL PANEL INSTALLATION.....	57
10.	ACCESSORIES AND SPARE PARTS	59
11.	CERTIFICATIONS	61
11.1.	CE accreditation.....	61
11.2.	Performance approvals.....	61
11.3.	Special conditions for safe use	62
12.	EU DECLARATION OF CONFORMITY	65
13.	TRANSLATION OF DATA LOGGER MESSAGES	67
14.	REQUIREMENTS FOR FUNCTIONAL SAFETY (SIL).....	69
14.1.	Basics	69
14.2.	Operation in safety related systems according EN 61508	69
14.3.	Definition of safety functions	69
14.4.	Configuration of WinPro / MX62	70
14.4.1.	Requirements for SIL 2 configurations	70
14.4.2.	Requirements for SIL 3 configurations	71
14.4.3.	Remarks for relay configuration	72
14.4.4.	Recommendations for increased availability	72
14.5.	Failure rates for WinPro / MX62 (PFD value)	73
14.6.	Directions for use in safety related applications	74

1. Presentation

WinPro[®] / MX62 is a stationary control system to be used in combination with a variety of detectors for continuous detection of combustible gases, toxic gases and oxygen.

Main features are a high reliability and flexibility. The flexibility refers to all areas, as there are free programmability, installation of relay and analog output modules and the optional installation in wall-mounted housings, 19 inch racks or control panels.

The modular components allow extension for up to 64 channels, 128 relays, 64 analog outputs and the optional use of an LCD module with data logger or profibus module, making the gas detection system suitable for all applications.

The complete system and all required modifications can be set by the software *ConfigPro*. This software is detailed separately.

2. System configuration

The system consists of a controller module plus various other modules linked by digital busses. The basic configuration is as follows:

- Analog input module (AEM)
- Controller module (CM)
- LED module
- LCD or logo module

The AEM converts the 4-20 mA signal of the detectors into digital bus signals to be transmitted to the CM. In the CM the signals are evaluated and separately indicated for each channel according to the respective presettings.

One AEM and one LED module are designed for eight channels each.

The CM can directly be employed for 64 channels on different input and output modules.

In addition the following modules can be integrated into the system as required:

- Basic relay module (RBM)
- Extension relay module (REM)
- Analog output module (AAM)
- Loop module (LOOPM)
- LCD data logger module

- Profibus module (PBM)
- Analog input extension module (AEAM)
- LCD copy module
- MIMIC module

Each RBM provides eight relays to be freely allocated. The REM allows the addition of eight relays with a minimum of space.

The AAM provides either 4-20 mA or 0-10 V outputs.

The AEAM can be used in combination with the AEM to connect smoke detectors at WinPro[®] / MX62.

All measured values and informations can be displayed with the LCD module and stored by a data logger.

2.1. Description of Modules

2.1.1. Controller module (CM)

The CM is the central control unit of the system for all 64 channels of maximum configuration. Two 16 bit micro controllers process the signals of the input modules redundantly.

The status of the relays and the output signals are transmitted to the relay and analog output modules by a redundant bus.

Another bus transmits the signals to the LCD and LED module. For safety control the CM also contains relays to signal system errors, emergency operation and service mode.

By means of an RS232 interface, the entire system can be configured and all data can be visualized on a PC.

A Centronics interface is available for connection of a printer.

2.1.2. Analog input module (AEM)

The detectors are connected to the AEM. Each module accommodates up to eight detectors with 4-20 mA signal output and provides an additional RS485 interface per channel.

By this interface, communication can be established in service mode between a PC, connected to the CM, and the respective digital detector.

Up to eight AEM can be connected to the CM. An address between 1 and 8 is allocated to each module by rotary switch.

2.1.3. LED Module

The status of each channel is indicated by LEDs. Each detector can be connected to any channel.

Operation of the buttons for the respective channels displays additional information about the connected detector on the LCD module and triggers further channel functions such as alarm suspension, operational test, channel disconnection and calibration mode.

The LED module consists of an LED panel for 16 channels and one or two PCBs for eight channels each.

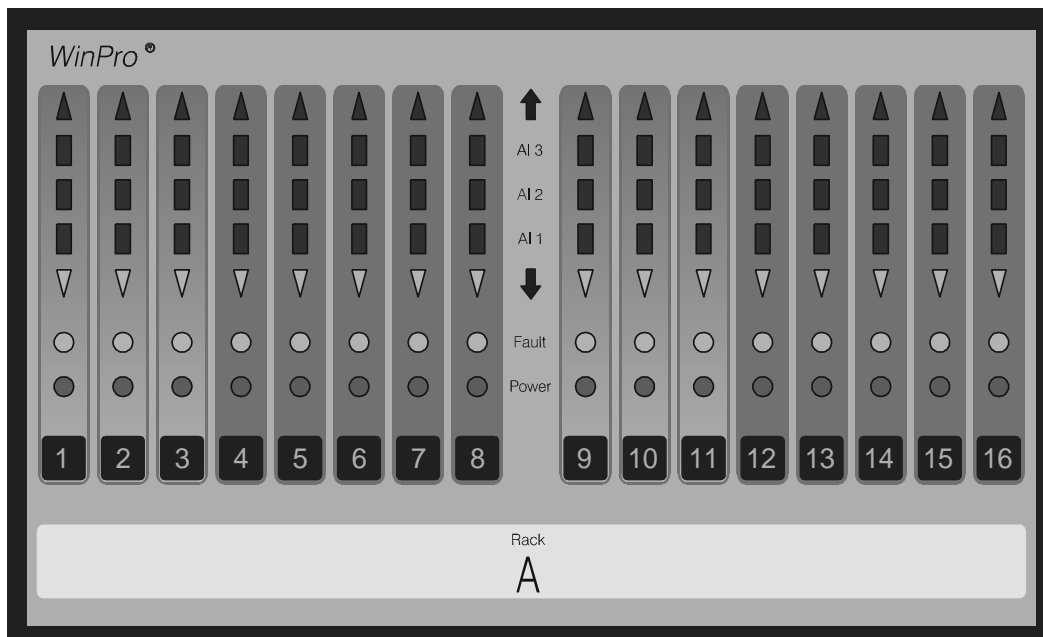

2.1.4. Basic relay (RBM) and Extension relay module (REM)

A RBM has eight relays and can be extended by eight relays with a pluggable REM.

Redundant triggering of the relays is done via two 8 bit micro controllers. Free parameter setting of the relays with the help of software *ConfigPro* meets all individual requirements:

- Open and closed circuit operation
- Grouping
- AND / OR logic operation
- Voting
- ADVANCED relay functions
- Time-delay and slow Release
- Buzzer relay function
- Relay reproduction

ATTENTION!

It is not allowed to use the ADVANCED relay functions in a safety related ATEX application with measuring function for explosion protection or a SIL application.

Up to eight relay modules with a total of 128 relays can be integrated into the system. The redundant, opto-isolated RS485 bus allows spatial separation (up to 800 m) of the modules and control unit.

An address between 1 and 8 is allocated to each module by rotary switch.

Open circuit:

The relays are activated as soon as the respective status is recognized, i.e. the relay inductor pick up.

Closed circuit:

The relays are activated in normal operation, i.e. the relay inductor have picked up, and will be deactivated in case of alarm, i.e. the relay inductor will be released.

2.1.5. Loop module (LOOPM)

The LOOPM for WinPro[®] / MX62 offers the possibility to build a network of digital detectors or to record signals of any standard 4-20 mA detector by means of AEM connected to the LOOPM.

The LOOPM can be employed in three different configurations:

- a) As regular Loop Module with up to 16 digital transmitters (e.g. TBGW EX) linked to the closed loop (address 1 to 16).

When using this type of configuration, no additional AEM can be connected.

- b) With one AEM and up to 8 digital detectors linked to the loop (address 9 to 16).

- c) With two AEM for connection of up to 16 standard 4-20 mA detectors. In this case, digital detectors cannot be linked to the loop.

Connection of digital detectors to the loop is realized by junction boxes (part no. 81090). Junction cables must not exceed a length of 30 cm.

ATTENTION!

When connecting digital detectors to the LOOPM, the current output (4-20 mA) inside the detectors has to be blocked with a shunt resistance of approx. 180 ohms between ground (GND) and current output (4-20 mA).

Furthermore, the two jumpers inside the detector for the bus end resistance (jumpers for RS485, next to the connection for power supply) need to be removed.

2.1.6. Analog output module (AAM)

The employment of up to eight AAMs with a total of 64 outputs allows transmission of detector signals (4-20 mA or 0-10 V).

An address between 1 and 8 is allocated to each module by rotary switch.

ATTENTION!

Though the AAM has two microcontrollers, only one controller is able to transmit data to the outputs. This is generally done by controller B. Since this will block transmission of measured values by controller A, same will be considered as faulty and the LED for fault will light up in red.

Should controller B be faulty, controller A will take over transmission of measured values to the outputs. In this case, the LED of controller A will light up in green and that of controller B in red.

2.1.7. LCD module

The system WinPro® / MX62 can be equipped with a graphic LCD display (240 x 128 pixels) showing information of measuring points, all relevant system parameters, system events and histograms.

The LCD module is provided with an integrated data logger with a storage capacity of up to 64 MB.

2.1.8. Logo module

If the optional LCD module is not used, the logo module will serve for display of the four LEDs indicating the status of the system. The logo module consists of the logo panel plus pertaining PCB.



2.1.9. Analog input extension module (AEAM)

The AEAM is intended for the connection of smoke detectors. It is possible to connect up to 8 smoke detectors at each AEAM.

The AEAM is an extension module and has to be plugged on the AEM.

ATTENTION!

It is not allowed to connect gas detectors to the AEAM.

2.1.10. LCD copy module

The LCD copy module is a modified LCD module. It offers the possibility to connect additional LCD displays (max. 30) to the display bus of the WinPro[®] / MX62.

The LCD copy modules have to be use only in combination with a standard LCD module (software version 2.05 or higher in needed).

In opposition to the LCD module it offers no data logging functionality and any interaction.

In normal operation mode it displays the logo of the company and the date. The backlight is off.

Each alarm on one of the 64 channels will be displayed by the LCD module and the LCD copy modules. The backlight will be activated automatically.

If there is more than one alarm at the same time, the affected channels will be displayed alternating for ten seconds.

The LCD copy module is subordinated to the LCD module. During interaction with the standard LCD module, e.g. a user wants to see information about one channel by pushing the channel button, the LCD copy module still shows the logo of the company, even if there is an alarm.

System messages are displayed by four LEDs.

The LCD copy modules are addressable (software V 2.18 or higher). The addresses are set during production. By setting a address it is possible to display the alarms selective. Modules with the address 0 are showing all messages. The configuration of selective messages has to be done by the software *ConfigPro*.

2.1.11. MIMIC Module

It is possible to copy the LED modules by using MIMIC modules.

The MIMIC module has to be connected to the display bus of the system WinPro[®] / MX62.

Each MIMIC module copies exactly one LED module. It is possible to connect a further LED module to the MIMIC module or to copy the primary LED module by using the open collector outputs of the MIMIC modules.

➔ *The MIMIC Module just shows status information of the channels. The buttons of the LED Module are deactivated.*

2.2. Redundancy of WinPro / MX62

The redundant structure of the system WinPro[®] / MX62 means that the complete safety functions are provided twice. From conversion of analog signals into bus signals to evaluation in the CM and relay connection, any single error will not lead to failure of the safety functions.

In addition, the two controllers of the CM continuously compare with each other. Thus, not only single-error-protection is achieved but also maximum availability.

To fulfill maximum safety criteria, the whole safety chain from detector to relay must be provided twice. Linking of detectors and relays can be carried out with the software *ConfigPro*.

2.3. Control Pane of WinPro / MX62

The control panel consists of at least one LED module indicating 16 channels and one logo module displaying the four LEDs for status monitoring.

Three further LED modules can increase the number of channels to 64. The LED modules are identified by letters of A to D. The channels are always numbered consecutively from 1 to 16.

Inputs		LED Module	Channel Identification	
from	to		from	to
1	16	A	A 1	A 16
17	32	B	B 1	B 16
33	48	C	C 1	C 16
49	64	D	D 1	D 16

The inputs can also be freely allocated to the LED modules with the software *ConfigPro*.

Using the optional LCD module, the four system LEDs are placed on the LCD module. The logo module is not used.

3. Operation of the System WinPro / MX62

During normal operation, the WinPro[®] / MX62 continuously processes signals of the connected detectors.

Besides, WinPro[®] / MX62 can enter into other modes for servicing or in case of malfunction. This chapter describes the various operating modes and the respective system performance.

3.1. Channel and System Information

As a standard, WinPro[®] / MX62 provides optical LEDs for the display of channel and system information.

Channel information:

Channel information refers to the respective detectors. The indication is done by seven LEDs for every channel on the LED module.

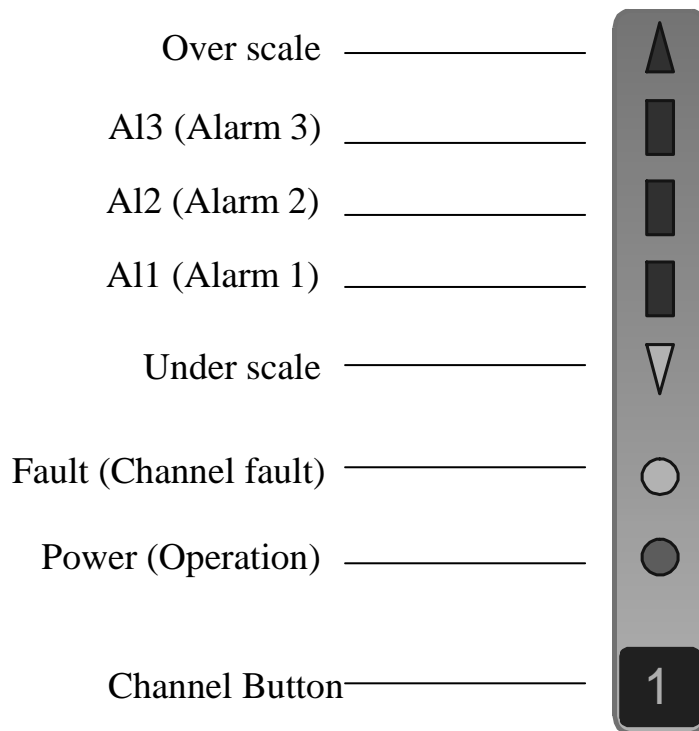

System information:

The four LEDs on the logo module or optional LCD module provide system information of the WinPro[®] / MX62 itself.

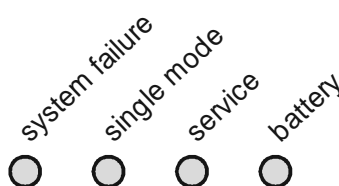

These blinking LEDs indicate a certain system status. For detailed description, please see:

- *System failure* (see chapter 3.6)
- *Single mode* (see chapter 3.5)
- *Service mode* (see chapter 3.4)

On the CM a separate relay output is allocated to each of these three modes.

The blinking LED *Battery* signals power failure, which provides an emergency power supply (optional).

Information of channel and system status can also be gained from the relay and analog transmitter signals.

➔ *In the following chapters the relay modules RBM and REM are explained. Details are given assuming a 1:1 relation between signal and relay output. Please note that this relation might not be valid when using the program ConfigPro to link several alarms or fault alarms in an installed system.*

3.1.1. ISA procedure (slow flashing channel LED)

For a better differentiation between “old” and “new” channel information it is possible to activate the ISA procedure by the software *ConfigPro*.

If the ISA procedure is activated, each new channel information will be shown by a slow flashing LED. After acknowledgement by the user the respective LED will light continuously or will set off (see chapter 3.3.7).

If the ISA procedure is not activated, a new alarm or a new channel fault is leading directly to a continuous lighting of the respective LED.

➔ *In this manual the description of the status of the channel LEDs is done for the deactivated ISA procedure.*

3.1.2. General buzzer relay

Beneath the three system relay outputs on the CM there is a further relay output for system information. This relay is activated for a short time (about 1 s) and is configurable by software as follows:

General buzzer relay:

The relay will be activated at each new alarm. This means that each new alarm can be indicated visually or acoustically. and/or

Warning for deactivated channels:

If the service rotary switch on the CM is moved from position 4 (activating/deactivating channel, see chapter 3.4.4) to another position and

minimum one channel is still deactivated, this relay will operate and the user is informed that not all channels are activated.

- ➔ *The alarm suppression and deactivation of a channel have effect on the activation of the general buzzer relay.*
- ➔ *The general buzzer relay will not be activated if a deactivated or an alarm suspended channel is triggered by an alarm.*

3.2. Sytem start-up

Upon start-up or directly after voltage cut-off, alarm signals are blocked for 1 to 10 minutes (setting by software *ConfigPro*). After the start-up mode, the system automatically enters into the operating status.

- ➔ *As many detectors signal undefined values after start-up, this mode eliminates any false alarms.*

During start-up the LEDs for system information can be checked. All four system LEDs are switched on for 0.5 s and those of the LED modules for 2 s.

The display of the LCD module is built up line by line.

Display, messages, outputs:

LED module:	LED <i>Power</i> and LED <i>Fault</i> are flashing
System:	LED <i>Service</i> is flashing, relay <i>Service</i> is activated
RBM/REM:	no relay is activated
AAM:	2 mA
LCD module:	display initialization and start-up messages
Printer:	message: <i>Cold reset</i> , software version

If a mean value is configured for a given channel, the calculation for the mean values starts new after re-entering the normal operation mode.

3.3. Normal Operation

The system automatically enters into normal operation once power has been supplied and the system has finished the start-up mode (see chapter 3.2).

During normal operation, both controllers of the CM carry out redundant measurement. Every channel that has been switched on will, depending on the measured value, enter into one of several possible states. The relevant green LED *Power* on the LED module will signal if a channel is switched on. This LED will start blinking as soon as the respective channel is shown on the LCD display.

3.3.1. Operating status

The measured signal is within the measuring range and the preset alarm levels.

Display, messages, outputs:

LED module:	LED <i>Power</i> is on
System:	all LED are off, no relay is activated
RBM/REM:	no relay is activated
AAM:	4-20 mA or 0-10 V (corresponding to the detected gas concentration)
LCD module:	normal operation (see chapter 4)
Printer:	no message

3.3.2. Alarms

The system WinPro[®] / MX62 has three free adjustable alarm levels within the measuring range of 4-20 mA.

The software *ConfigPro* allows, for example, adjusting of alarm levels, latching of alarms or setting of alarm thresholds for mean values within a specified time. Furthermore, alarms can be triggered in case of over or under run of alarm levels.

For numerous target gases, preset measuring profiles are available in *ConfigPro*.

Display, messages, outputs:

LED module:	corresponding LED <i>Alarm</i> are on
System:	all LED are off, no relay is activated
RBM/REM:	corresponding relays <i>Alarm 1</i> , <i>Alarm 2</i> and/or <i>Alarm 3</i> are activated
AAM:	4-20 mA or 0-10 V (corresponding to the detected gas concentration)
LCD module:	message: <i>Alarm 1</i> , <i>Alarm 2</i> and/or <i>Alarm 3</i>
Printer:	message: <i>Al1</i> , <i>Al2</i> and/or <i>Al3</i>

3.3.3. Channel fault

In case of channel malfunction, the measured signal has either fallen below 2 mA or exceeded 24.5 mA. Channel malfunction could, for example, mean interruption or short circuit of the signaling line. The detector may also be defective.

It is also possible that communication with AEM or LOOPM is interrupted. In this case, all channels go into the fault mode about 30 seconds following loss of communication.

In case the communication with an AEM or LOOPM fails, all corresponding channels will show fault inbetween 10 s.

This signal is not latching (see chapter 3.7).

Display, messages, outputs:

LED module:	LED <i>Fault</i> is on
System:	all LED are off, no relay is activated
RBM/REM:	corresponding relay <i>Fault</i> is activated
AAM:	4-20 mA: signal output of detector
	0-10 V: 0 or 10 V
	in case of communication error: 0 mA or 0 V
LCD module:	under or over scale
	(see chapter 3.3.4 or 3.3.6)
	message: <i>Fault</i> and if over scale is non-latching: <i>Short circuit</i>
Printer:	message: <i>FLT</i>

ATTENTION!

The gas detection system WinPro[®] / MX62 differentiates the faults of a specific channel from those of the complete system (chapter 3.6). If channel malfunctions have to trigger an external measure automatically, the signals in configuration need to be allocated to one or several relay outputs.

One relay output must always be configured as collective relay if application is according to EU certificate BVS 03 ATEX G 002 X.

3.3.4. Negative measured values

The measuring signal is below zero but above the threshold mentioned in chapter 3.2.5 for under scale of measuring range. Zero fluctuations of the detectors are within the normal and acceptable range of deviations.

Display, messages, outputs:

LED module:	LED <i>Power</i> is on
System:	all LED are off, no relay is activated
RBM/REM:	no relay is activated
AAM:	4-20 mA: signal output of detector
	0-10 V: 0 or 10 V
LCD module:	measured value: > -3% of range: 0
	< -3% of range: <0
Printer:	no message

3.3.5. Under scale (US)

In case of under scale, the signal of the detector is below a preset threshold which is generally -5% of the detection range. (Deviating

values up to a maximum of –10% of the detection range can only be configured by OLDHAM). Though the detector should be calibrated measuring is still given.

The signal is not latching.

Display, messages, outputs:

LED module:	LED <i>Under scale</i> (arrow down) is on
System:	all LED are off, no relay is activated
RBM/REM:	corresponding relay for under scale is activated
AAM:	4-20 mA: signal output of detector
	0-10 V: 0 V
LCD module:	measured value: <0
	message: <i>under scale</i>
Printer:	message: <i>US</i>

3.3.6. Over scale (OS)

As standard the threshold for over scale equals the upper range value.

➔ *Optional the threshold value can be set below the end scale value (a specific configuration with ConfigPro is needed). In this case the behavior of the WinPro at over scale is the same as normal alarm mode (see chapter 3.3.2).*

In case of over scale, the signal of the detector will be higher than 20 mA. Detection is still given but the signal is above the detection range. The measured value can only be defined as concentration above the end scale value but no indication is available how far the end scale value has been exceeded.

Usually, this alarm is configured to be latching.

➔ *Some detectors require special action to be taken after they have been exposed to high gas concentrations. Calibration and adjustment might become necessary. Please refer to the recommendations in the manuals for the respective detectors.*

Display, messages, outputs:

LED module:	LED <i>Over scale</i> (arrow up) is on
System:	all LED are off, no relay is activated
RBM/REM:	corresponding relay for over scale is activated
AAM:	4-20 mA:
	latching alarm: 22 mA
	non-latching alarm: signal output of detector
	0-10 V: 10 V

LCD module:	measured value: end scale value with profiles $x\%$ <i>LEL</i> or <i>LEL</i> : > end scale value measured value is frozen
	message: <i>Over scale</i>
Printer:	message: <i>OS</i>

3.3.7. Resetting of Alarm Signals

There are two different types of resetting:

Resettable:

Resetting of audible alarm signals: Relays can be configured to be reset even if alarm condition is still present.

In general, these should, however, exclusively be employed for the triggering of buzzers, sirens and other audible alarm indicators.

Latching Alarms:

Resetting of latching alarm signals: A latching alarm signal will be extant even if the gas concentration diminishes. The alarm signal (with the allocated relays) can only be reset after the gas concentration has fallen below the alarm level.

Resetting is done by pressing the button for the respective channel on the LED module. Resetting is also possible by the external reset input (ext. reset). In this case, all resettable messages will be resetted.

The behavior of a channel, when resetted, depends on the activation of *ISA procedure* (see chapter 3.1.1).

ISA procedure activated:

- In case an LCD module is used, operating the button **first time** is for the LCD display.
 - Operating the button **second time** resets an existing resettable relay and the blinking channel LED will light continuously.
 - Operating the button **third time** resets a latching alarm signal (gas concentration < alarm threshold).
- ➔ Should neither an LCD module nor a relay for audible alarm signals be employed, the latching alarm signal will be reset when the button is operated first.

ISA procedure deactivated:

- In case an LCD module is used, operating the button **first time** is for the LCD display.
- Operating the button **second time** resets an existing resettable relay.

- Operating the button **third time** resets a latching alarm signal (gas concentration < alarm threshold).
- ➔ Should neither an LCD module nor a relay for audible alarm signals be employed, the latching alarm signal will be reset when the button is operated first.

3.4. Service Mode

This mode is for service and modification of the gas detection system.

For the various functions available in the service mode, the rotary switch on the CM has to be set to the respective position (switch positions 1 to 5). The number is indicated on the pertaining LED display (see chapter 7.1).

Channel selection:

After positioning of the rotary switch (except position 5 for PC communication), one or several channels can now successively be entered into a selected function for servicing by operating the respective button for more than two seconds. After two seconds have elapsed, all LEDs for the relevant channel briefly light up. Only after releasing the button, the respective function is available.

Completion of service:

Completion of service of the relevant channel will be effected by operation the respective button once again for more than two seconds or the maximum time preset for service is exceeded (set by software *ConfigPro*).

With the switch on the CM in position 0, the service mode is closed and the unit is back to normal operation. The yellow LED *Service* switches off.

3.4.1. Alarm suspension (switch position 1)

The suspension of alarms prevents that relays which are related to alarms, faults, over- or under scale are not taken into account and are consequently not triggered.

A general alarm suspension is possible as described in chapter 3.4.7.

Display, messages, outputs:

LED module:	LED <i>Fault</i> flashes, LED <i>Alarm, Fault, Under scale</i> (arrow down) and <i>Over scale</i> (arrow up) flash if condition is given
System:	LED <i>Service</i> is on, the relay <i>Service</i> is activated when one channel is selected
RBM/REM:	all corresponding relays are deactivated
AAM:	2 mA or 0 V
LCD module:	message: <i>Alarm suspension</i>
Printer:	message: <i>Service relay activated</i>

ATTENTION!

Previously activated relay outputs are reset when, after selecting alarm suspension, conditions for triggering these relays are no longer given.

Alarm suspension must not be used for calibration purposes.

3.4.2. Operational test (switch position 2)

This operational test allows checking of channel LEDs, relay and analog outputs.

➔ *The operational test simulates the triggering of all signals and alarms. After the operational test has been completed, any triggered alarm will be reset only if the measured value is below the alarm threshold (including configured alarm hysteresis).*

Display, messages, outputs:

LED module:	LED <i>Fault</i> flashes, all other channel LEDs are on
System:	LED <i>Service</i> is on, the relay <i>Service</i> is activated when one channel is selected
RBM/REM:	all relays are activated
AAM:	over scale (see chapter 3.3.6)
LCD module:	over scale (see chapter 3.3.6)
	message: <i>Operational test</i> and other channel related messages e.g. alarms
Printer:	message: <i>Service relay activated</i>

3.4.3. Calibration (switch position 3)

This function allows calibration and adjustment of detectors. Outwardly, the system operates as it does with alarm suspension (see Chapter 3.4.1).

Display, messages, outputs:

LED module:	LED <i>Fault</i> flashes, LED <i>Alarm, Fault, Under scale</i> (arrow down) and <i>Over scale</i> (arrow up) flash if condition is given
System:	LED <i>Service</i> is on, the relay <i>Service</i> is activated when one channel is selected
RBM/REM:	all corresponding relays are deactivated
AAM:	2 mA or 0 V
LCD module:	message: <i>Calibration</i>
Printer:	message: <i>Service relay activated</i>

3.4.4. Channel on/off (switch position 4)

In switch position 4 a detection channel can be deactivated by pressing the corresponding channel button on the LED module.

Should a channel be deactivated, the measured signal is no longer evaluated.

Alarm and fault conditions on the deactivated channel will not be signalled. The corresponding LEDs and relay will not be activated.

Channel deactivation will be extant even after the service mode is closed.

The channel can be re-activated by renewed selection.

ATTENTION!

Even if the channel is switched off, the detector will be powered with 24 V. For works to be carried out in hazardous areas, power to the detector must be disconnected.

For safety reasons, an alarm is internally signaled when deactivating a channel being in an AND or VOTING operation. The alarm will, however, not be shown on the LED module. This evaluation may cause alarm signaling with an AND or VOTING operation of channels, even though this should not be the case according to the displays of the LED modules.

Display, messages, outputs:

LED module:	all LEDs for deactivated channels are off
System:	LED <i>Service</i> is on, the relay <i>Service</i> is activated when switch in position 4 and one channel is deactivated or even selected for deactivation
RBM/REM:	all corresponding relays are deactivated
AAM:	2 mA or 0 V
LCD module:	deactivated channel is not displayed
Printer:	message: <i>Service relay activated</i>

3.4.5. PC communication (switch position 5)

PC communication allows external access to the system WinPro[®] / MX62, e.g. for changing the configuration with software *ConfigPro*.

Measurement and evaluation are continued as long as no command via PC communication is given that requires quitting the measuring mode.

➔ *During UPLOAD (see operation manual for software ConfigPro) of a changed system configuration, first of all an alarm for system error is triggered. After resetting, the system will be re-started with the changed configuration (see chapter 3.2).*

Display, messages, outputs:

LED module:	as operation status
System:	LED <i>Service</i> is on, the relay <i>Service</i> is activated when a PC is logged
RBM/REM:	as operation status

AAM: as operation status
 LCD module: as operation status
 Printer: as operation status

3.4.6. Ignore communication fault with relay modules (switch position 6)

This function allows the replacement of a defective relay module during the normal operation mode without setting a system failure message.

In normal operation mode a replacement of a defective relay module would cause a communication fault with relay modules and the system would have a system failure.

To activate this function turn the rotary switch into position 6 and push the reset buttons of both controllers.

If the rotary switch is in position 6, all communication errors with relay modules will be ignored for 30 minutes.

To deactivate this function turn the rotary switch into position 0 and push the reset buttons of both controllers again.

The system will go into a system failure if the function is activated longer than 30 minutes and a message will be displayed on the LCD module and/or the CM.

ATTENTION!

The new relay module has to be of the same hardware type as the replaced. The replacement e.g. of a RBM+REM by a RBM is not allowed and causes a system failure.

Display, messages, outputs:

Indication during 30 minutes:

LED module: as operation status
 System: LED *Service* is on, the relay *Service* is activated
 RBM/REM: as operation status
 AAM: as operation status
 LCD module: message: *Service mode*
 Printer: message: *Service relay activated*

Indication after 30 minutes:

LED module: all LED *Fault* are on
 System: LED *System failure* is on, the relay *Service* is activated
 RBM/REM: as operation status
 AAM: as operation status
 LCD module: message: *System failure*
 Printer: message: *Failure relay activated*

➔ *During replacement of the defective module disturbances on the output bus are possible, e.g. relays of other relay modules can be affected and switch.*

3.4.7. General alarm suspension

The general alarm suspension is a special case of the channel depended alarm suspension. If activated, all channels are in the operation mode *alarm suspension*, independent of the position of the rotary switch at the CM.

For activation of the general alarm suspension two analog input channels are needed. The two channels have to be configured in a special manner by the software *ConfigPro*.

The general alarm suspension is activated when both special configured channels have an alarm.

The general alarm suspension is deactivated when both special configured channels have no alarm.

Configuration of the analog inputs:

A key switch with two independent contact pairs is needed.

When not switched (position *0*), on both channels a signal current of 4 mA will be simulated using a 6k resistor.

In the switched position (position *1*, general alarm suspension activated) at one channel a signal of 8 mA will be simulated using a 3k resistor and at the other channel a signal of 14 mA using a 1k7 resistor.

ATTENTION!

Only authorized and instructed persons are allowed to use the key switch.

It is not allowed to connect gas detectors to the channels for general alarm suspension!

3.5. Single mode

In this mode, full redundancy is no longer given or comparison of the two controllers with each other is disturbed. Measurement will still be done correctly and all safety functions are maintained. In particular, switching of relay outputs is guaranteed. Since channel indication on the LED modules and the LCD module is linked to one of the two controllers, information will not be available if the respective controller is faulty (see chapter 3.7).

ATTENTION!

If WinPro[®] / MX62 changes into single mode, immediate measures must be taken to cancel redundancy loss.

Display, messages, outputs:

LED module:	as operation status or all LED <i>Fault</i> are flashing
System:	LED <i>Single Mode</i> flashes, the relay <i>Single mode</i> is activated
RBM/REM:	as operation status
AAM:	as operation status
LCD module:	message: <i>Single mode</i> or display failure
Printer:	message: <i>Emergency operation relay activated</i>

3.6. System failure

In this case, the safety function has failed (see chapter 3.7). Two separate errors have occurred in the WinPro[®] / MX62.

The system failure is only indicated after the system has tried to maintain the measuring function by resetting. During this time, the system operates as if it is in start-up mode though the outputs of the relay modules are not reset.

Depending on the configuration of the system, there can be a time delay of up to 90 s between error occurrence and indication.

ATTENTION!

The gas detection system WinPro[®] / MX62 differentiates the faults of the complete system from those of a specific channel (chapter 3.3.3).

When configuring safety control devices to be connected to the system, please bear in mind that a system error does not automatically lead to activation of all relay outputs for channel malfunctions. In this case, the switch position of the relay *System failure* has to be taken in account.

Display, messages, outputs:

LED module:	all LED <i>Fault</i> are on
System:	LED <i>System failure</i> is on, the relay <i>System failure</i> is activated
RBM/REM:	status at begin of system failure will remain
AAM:	0 mA or 0 V
LCD module:	message: <i>System failure</i> or display failure
Printer:	message: <i>Failure relay activated</i> or printer failure

3.7. Measures against Faults

Display:	Possible Reason:	Measures against Faults:
LED <i>Fault</i>	<ul style="list-style-type: none"> Line disconnection Insulation defect Defective detector Wrong connected line A detector signal has exceeded 24.5 mA. <p>(Attention! Danger!)</p>	<ul style="list-style-type: none"> Measure signal current Check connection Check gas concentration separately, e.g. with portable detector Check detector and replace, if necessary
All LEDs <i>Fault</i> are on and LED <i>System failure</i> is blinking	<ul style="list-style-type: none"> Timeout for <i>Ignore communication faults with relay modules</i> 	<ul style="list-style-type: none"> Turn the rotary switch into position 0 and reset both controller
Part of LEDs <i>Fault</i> are on; no LED for system information is on.	<ul style="list-style-type: none"> An AEM is defective or not connected. An AEM is addressed wrong. 	<ul style="list-style-type: none"> Check connection between AEM and CM Check 24V power supply Check address of AEM Replace AEM Check configuration with software <i>ConfigPro</i> Check detector and replace, if necessary
All LEDs <i>Over-</i> and <i>Under scale</i> are blinking; the remaining LEDs for channel and system information are off.	<ul style="list-style-type: none"> Communication error between CM and display <p>(In this case, safety functions are fully maintained by the relays.)</p>	<ul style="list-style-type: none"> Check connection between CM and display
LED <i>Single mode</i> is blinking.	<ul style="list-style-type: none"> Malfunction of controller B 	<ul style="list-style-type: none"> Evaluate error code on the CM
LED <i>Single mode</i> is blinking; all LEDs <i>Fault</i> are blinking.	<ul style="list-style-type: none"> Malfunction of controller A 	<ul style="list-style-type: none"> Evaluate error code on the CM
LED <i>Fystem failure</i> is blinking; all LEDs <i>Fault</i> are on.	<ul style="list-style-type: none"> Both controllers of the CM are defective. Interruption of connection to all AEM Interruption of connection to at least one relay module 	<ul style="list-style-type: none"> Evaluate error codes on the CM Check connection between AEM and CM Check connection between relay module and CM
Analog outputs: 0 mA or 0 V; channel LEDs <i>Fault</i> are off.	<ul style="list-style-type: none"> Defective AAM Interruption of connection between AAM and CM 	<ul style="list-style-type: none"> Replace AAM Check connection between AAM and CM
LED <i>Battery</i> is blinking.	<ul style="list-style-type: none"> Emergency power supplied 	<ul style="list-style-type: none"> Check mains supply
All LEDs <i>Fault</i> and <i>Operation</i> are blinking.	<ul style="list-style-type: none"> Power failure logic in operation – no malfunction! 	<ul style="list-style-type: none"> After the preset time for power failure logic, the system automatically returns to normal operation.
Wrong indication of date/time after power failure	<ul style="list-style-type: none"> Buffer battery on the CM is exhausted (expected life time \geq 10 years) 	<ul style="list-style-type: none"> Replace battery Adjust setting via <i>ConfigPro</i>

➔ *After rectifying system errors, a resetting of the micro controllers on the modules might be necessary. The CM should always be resetted at last. The reset keys are positioned on the modules (see chapter 7).*

3.8. Error Codes of the CM

The redundant controllers A and B on the CM have both an LED display (status μ C) for indication of error codes, assisting fast repair of any malfunction of the gas detection system by simplifying the search of errors within a limited range. Always of the first error recognized by the system is indicated. Only *error code 20* can be overwritten by an error recognized later on.

Code	Description of Error
3	Controller A (or B) has activated its fault release, the cause for it can however not be determined.
4	DPRAM error; the status of Controller A (or B) cannot be read by the DPRAM.
10	The printer is offline.
11	No paper in the printer.
12	DATA LOGGER: Storing chip is filled to capacity.
20 (only CPU A)	Failure in LED Module addressing. Be sure that the number of connected LED Modules is the same as the number of configured input modules (in groups of eight).
21	Error in automatic recognition of LED Modules: Recognized addresses are not consecutive or incomplete.
40	No valid values in the parameter memory.
41	Checksum error in flash memory.
42	Incomplete upload. Not all parameters set have successfully been loaded or initialized.
43	Incomplete configuration. No channels have been configured.
44	Error in loading or deleting the flash memory.
45	The system has not been activated.
46	The system could recognize several successive power failures.
47	The Controller has received instruction for RESET from the RS232 interface.
48	Error in configuration of input modules: e.g. Loop Module has an even address
60	The running time of the program (loop time) has been exceeded repeatedly.
61	Error in communication with the Analog Input Module. The measured values cannot be read within the preset short period of time.
62	Error in memorizing measured values. No module can memorize any measured values.
63	Communication error with one or several relay modules.
64	Configuration error: Please check configuration of relay modules.
65	Time exceeding for <i>Ignore communication fault with relay modules (switch position 6)</i>
70	Hardware malfunction: The READY line remains at high level after reset.
71	Hardware malfunction: The RESET line remains at high level after reset.
72	Hardware malfunction: The RESET line remains at low level after reset.
73	Hardware malfunction: The fault relay is active during resetting.
74	Hardware malfunction: The fault relay does not switch.
77	Hardware malfunction: Error in testing of external UART (output modules).
79	Hardware malfunction: Overrun of external UART (output modules).
80	Hardware malfunction: Error in testing of internal RAM.
81	Hardware malfunction: Error in testing of external watchdog.
82	Hardware malfunction: Error in testing of flash ROM.
83	Hardware malfunction: Error in testing of external RAM.
84	Hardware malfunction: Verification error after loading into the EEPROM.
85	Software error: Variable outside the valid range.

86	Hardware malfunction: Error in testing of internal UART.
87	Hardware malfunction: Error in testing of external UART (input modules).
88	Processor is in the course of resetting which will be completed after a few seconds.

The following messages of digital detectors can be displayed if a LCD module is used. Measures against faults are described in the respective manuals.

error	(F) Error internal positive supply
error	(F) Error internal negative supply
error	(F) Defective sensor heating voltage
error	(F) Defective sensor bias voltage
error	(F) Defective 4-20 mA
error	(F) Transmitter: internal overflow
error	(F) Zero drift too large
error	(F) Sensitivity too low
error	(F) No permissible sensor exchange
error	(F) ISB EEPROM defective
error	(F) Transmitter ROM defective
error	(F) Transmitter RAM defective
error	(F) Transmitter EEPROM defective
warning	(W) Relative humidity too low
warning	(W) Relative humidity too high
warning	(W) Below permissible pressure
warning	(W) Above permissible pressure
warning	(W) Below set temperature
warning	(W) Above set temperature
warning	(W) Zero drift too large
warning	(W) Sensitivity too low
warning	(W) No permissible sensor exchange
warning	(W) Sensor defective (fracture)
warning	(W) Sensor voltage too low
warning	(W) AK: Test gas not stable
warning	(W) Maintenance rate exceeded

3.9. Overview of LED indications

The following tables show the various possibilities of indication by the LED modules and the LEDs for system information.

Besides the channel status, information on the system status can also be signaled in case of malfunction.

ATTENTION!

The tables below show the possibilities of indication when the ISA procedure is deactivated. For detailed information see chapter 3.1.1.

Channel-related Indications:

LEDs	Standard	Channel selected (LCD)	Alarm suspension	Calibration	Operational test	Power failure logic
Over scale	on/off	on/off/ blinking	off/blinking	off/blinking	on	off
Alarm 3	on/off	on/off/ blinking	off/blinking	off/blinking	on	off
Alarm 2	on/off	on/off/ blinking	off/blinking	off/blinking	on	off
Alarm 1	on/off	on/off/ blinking	off/blinking	off/blinking	on	off
Under scale	on/off	on/off/ blinking	off/blinking	off/blinking	on	off
Fault	on/off	on/off/ blinking	blinking	blinking	blinking	blinking
Power	on	blinking	on	on	on	blinking
Single Mode	off	off	off	off	off	off
System Failure	off	off	off	off	off	off
Service	off	off	blinking	blinking	blinking	blinking
Battery	blinking/off	blinking/off	blinking/off	blinking/off	blinking/off	blinking/off

System-related Indications:

LEDs	Commu- nication Error (*1)	Error in LEDM Addressing (*4) (Error Code 20)	Single Mode μ CA: ok μ CB: error	Single Mode μ CA: error (*2) μ CB: ok	System Error μ CA: error μ CB: error
Over scale	all blinking	all blinking	on/off/blinking	off	off
Alarm 3	off	off	on/off/blinking	off	off
Alarm 2	off	off	on/off/blinking	off	off
Alarm 1	off	all blinking	on/off/blinking	off	off
Under scale	all blinking	all blinking	on/off/blinking	off	off
Fault	off	off	on/off/blinking	all blinking (*3)	all on (*3)
Power	off	off	on/off/blinking	off	off
Single Mode	off	blinking/off	blinking	blinking	off
System Failure	off	blinking/off	off	off	blinking
Service	off	blinking/off	off	off	off
Battery	off	blinking/off	blinking/off	blinking/off	blinking/off

- (*1) The LED Modules do not receive any data from the Controller Module (Controller A).
- (*2) In this single mode, LED Modules do not receive any information on status of channels. The safety function of the system is, however, fully maintained.
- (*3) The respective LEDs of all channels on the LED Module are activated, i.e. including channels not used or deactivated.
- (*4) This error code is exclusively indicated on CPU A (the fault relay will not be activated). Be sure that the number of connected LED Modules is identical with the number of input channels. The number of connected LED Modules must not be more or less.

4. Operation of LCD module

The optional LCD module is operated by its four buttons as well as those for the respective channels.

Besides display of the individual channels indicating information on measuring points and system events, menu-driven operation allows calling up of all settings and information plus controlling of data logger and printer.

4.1. Display of channels

Normal operation:

- The company logo is displayed. By operating a button of any channel, the respective channel information is shown for 60 minutes - indicating information of measuring point, system parameters as well as events. Afterwards, the display returns to the logo automatically.
- When operating an arrow button during channel display, the following channel is indicated next to the one currently shown.
- By the menu item for LCD settings (see following chapter), two different displays can be selected:
 - After operating an arrow button while the logo is displayed, all channels will successively be switched through their full range in rising order, i.e. the display of each channel changes every 5 seconds. After all channels have been shown, the display returns to the logo.
 - Alternatively, constant scrolling of the display for all activated channels can be set by the menu.

Alarm:

- In case of alarm, the respective channel is automatically displayed. If several channels are affected, these will automatically be scrolled through.
- While alarm for one or more channels is indicated, any channel can be displayed by constant operation of the respective button. As soon as it is released, alarm for the channels is once more indicated.
- Any system events are indicated while the logo is displayed.

4.2. Menu

By operating the buttons *OK* or *ESC* while the logo is displayed, the main menu is entered in which various settings can be modified or information be obtained.

While the unit is in service mode, i.e. during *PC communication*, values can only be read and not changed.

The menu is left 60 seconds after the last operation automatically and the display returns to the logo display.

Generally, the following applies for any operation of the menu:

- *OK button*: for going one menu level lower or acknowledgement of entry and modification respectively
- *ESC button*: for going one menu level higher or rejection of entry and modification respectively.
- *Arrow buttons*: for scrolling within a menu or change of values

4.2.1. System / LED-test

The LEDs of all LED panels are activated by this menu item.

4.2.2. System / System status

The current system status is indicated.

4.2.3. System / System information

Indication of system information such as:

- actual software version
- order number
- serial number
- next date for service

4.2.4. Channel information / Actual information

After the respective channel has been selected with the aid of the arrow buttons, current channel information is displayed. This menu corresponds with operating the button for any channel during normal operation (see chapter 4.1).

4.2.5. Channel information / Display of configuration

After selecting the respective channel with the aid of the arrow buttons, the actual status of the channel (activated, deactivated etc.) as well as the actual channel configuration is displayed.

4.2.6. Relays

The respective relay is selected by the arrow buttons. For selection, only configured relays are taken into consideration and displayed. After selection of a relay, its configuration is indicated.

4.2.7. Analog outputs

The respective analog output is selected by the arrow buttons. For selection, only configured analog outputs are taken into consideration and displayed. After selection of an analog output, its configuration and actual value are indicated.

4.2.8. Datalogger / Set-up

After selection of the respective channel, data recording for this channel can be configured.

The modes *8-hour mean value* as well as *Recording* can be activated or deactivated. With *Recording* being activated, the *Recording mode* may also be set.

With continuous recording, the measured values of the selected channel are constantly stored.

With event recording, only events of the respective channel are recorded.

➔ *Modifications for recording of a channel can only be effected if the rotary switch on the controller module is not in position 5 (PC communication).*

4.2.9. Datalogger / Histogram

After selecting the respective channel by the arrow buttons, the histogram of the channel is displayed.

By means of this histogram, gas concentrations can be monitored over a longer period of time.

To see the concentration prevalent at a certain time, a cross is moved to the respective position with the aid of the arrow buttons. This cross is found on the X-axis. The gas concentration measured as well as any active alarm signal at the time is shown in the upper margin of the LCD.

By operating the button *OK*, the histogram can be deleted.

Recording intervals may be set in the menu *Datalogger* of the configuration software *ConfigPro*.

4.2.10. Datalogger / Events

At first, general information on events is shown such as number of all events from beginning of the recording, start of recording, date of latest event, etc.

In addition, a menu is displayed for selecting the next step:

Show events:

All events are shown in chronological and declining order, i.e. the most recent events come first.

The channels are indicated on the LED module according to their configuration, e.g. A03 means *rack A, channel 3*.

As to the display of relays, first the module address and then the relay number is shown, e.g. M8 R3 means *relay module 8, relay No. 3*.

Delete events:

In this menu item, all stored events are deleted.

4.2.11. Datalogger / 8-hour mean values

After selecting the respective channel with the aid of the arrow buttons, stored mean values are shown.

For this, however, the recording of mean values need to be activated for the respective channel by the configuration software *ConfigPro*.

4.2.12. Datalogger / Format

On the one hand, this menu item can be used to format the memory card. On the other hand, general information of the memory card is shown.

4.2.13. Printer settings

The printer can be activated or deactivated.

➔ *Activation or deactivation of the printer can only be effected if the rotary switch on the controller module is not in position 5 (PC communication).*

4.2.14. LCD settings

LCD settings can be modified by this menu item. For this, the entry to be modified is selected by the arrow buttons, after which the button *OK* is operated.

Language:

The menu language of the LCD can be selected. Options are: English, German, French, Spanish and Dutch.

ATTENTION!

Changing the language only refers to the menu structure. Designations regarding channel information such as measuring point description, target gas etc. are not affected. Such designations can only be changed with the aid of the configuration software *ConfigPro*.

Contrast:

By the arrow buttons, contrast can be increased or decreased.

Scroll mode:

As already mentioned in chapter 4.1 operation of the arrow buttons allows the actual measured values of all configured and activated channels to be automatically shown for approx. 5 seconds while the company logo is displayed.

This parameter can change the scroll mode:

- *Off:* The channels are not scrolled through.
- *Once:* All configured and activated channels are scrolled through once. When the last channel has been shown, the company logo will be displayed again.
- *Continuous:* All configured and activated channels are continuously shown.

Background light:

This parameter determines when the display is to be backlit:

- *Constant:* The background light is always activated.
- *Key is pressed:* The background light of the display is only switched on when a button is pressed. It makes no difference whether a button of the LCD module or a key for a respective channel is operated.
- *Events:* The background light of the display will be activated if any event occurs. This includes alarms and operating the buttons of the LCD module or those for a respective channel.

Rate of repetition:

If the button *ESC* is operated while a system event is shown, the display will return to the company logo.

After a certain period of time, the display changes back to the system event in case the fault is still prevailing.

This period of time can be set with this parameter.

LCD copy number:

For determination of the LCD copy module address for the LCD copy filter see chapter 2.1.10. Each LCD module has automatically the address 0. Changing the address of an LCD module has no consequences.

The structure of the menu is shown on the following page:

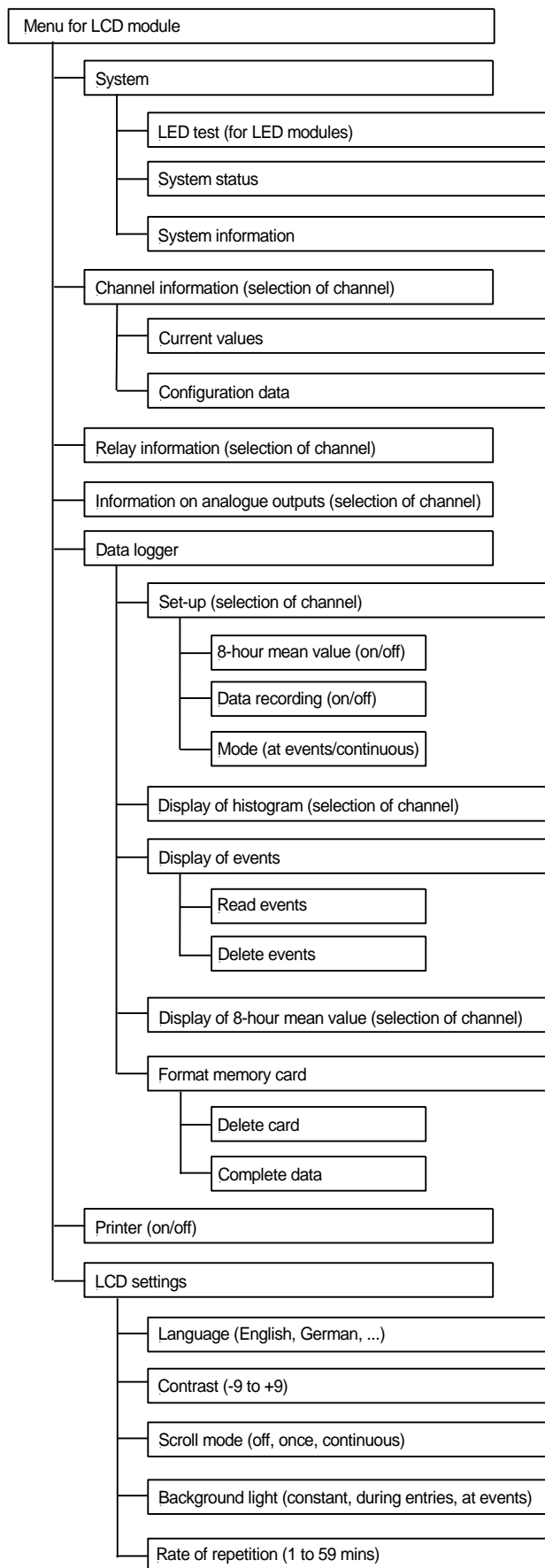

5. Commissioning and maintenance

Attention!

Service and maintenance activities for gas warning and detection systems have to be done by trained and authorized personnel.

Record keeping has to be done for all service and maintenance activities.

Commissioning and maintenance of gas warning and detection systems has to be done following the requirements of the european standards EN 60079-17, EN 60079-29-2 and/or EN 45544-4. Additional national regulations (e.g. german „Merkblatt T023“ or „Merkblatt T021“ of BG RCI) and the manuals of the connected detectors have to be observed.

At commissioning and in a regular interval (depending on connected detectors and the industrial application), but minimum once a year, the following work has to be done:

- Inspection and adjustment of detectors according manuals (or more often)
- Inspection of alarm triggering
- Performance inspection of all relays contacts
- Test of visual and acoustical warning signals of the detection system (for functional test see chapter 3.4.2)

➔ *For inspection of alarm triggering following test gas concentrations are needed:*

- Monitoring of lower explosion limit (LEL), inerting and oxygen enrichment: A test gas concentration maximum 10% above main alarm level

- Monitoring of oxygen deficiency: A test gas concentration maximum 10% below the main alarm level

For safe and regular maintenance we provide you service contracts for your gas detection system. With our skilled and trained service technicians we will give you a high level of safety and confidence in your safety devices. Please contact:

Oldham S.A.S.

Rue Orfila

Z.I. Est – CS 20417

F – 62027 ARRAS Cedex

Tel: +33 (0)3 21 60 80 80

Fax: +33 (0)3 21 60 80 00

Internet: www.oldhamgas.com

E-mail: info@oldhamgas.com

5.1. Calibration and adjustment

The system WinPro[®] / MX62 provides three different methods of calibration that depend on the detector to be calibrated as well as the prevailing conditions on site.

5.1.1. Direct calibration at the detector

DetectorsTransmitters with a standardized output of 4-20 mA are directly adjusted with, for example, the aid of potentiometers fitted inside the detectors.

This calibration is carried out with the function for calibration of the service mode to avoid triggering of relays.

5.1.2. Remote calibration for standard detectors

It is possible to adjust standard 4-20 mA detectors without actually accessing the detectors directly.

This remote calibration can be carried out in the service mode *PC communication* by adjusting the 4-20 mA output of the WinPro[®] / MX62 within a preset range by means of special software *RemoteCalibrationPro*.

ATTENTION!

Since evaluation of the 4-20 mA input signal is altered, the signal of 4-20 mA needs to be reset in case the detector is replaced or directly calibrated. This is achieved by the function *Calibration* of the service mode.

5.1.3. Manual and automatic field adjustment of digital detectors

The digital detectors of WINTER, e.g. TBGW EX, have a 4-20 mA analog as well as a RS485 connection to the WinPro[®] / MX62. The latter serves for transmission of additional data during normal operation as well as for adjustment.

Adjustment is detailed in the operation manuals for digital detectors and carried out with the help of software *ConfigEx*.

6. Technical Data

Parameter	Description
Detection channels	up to 64 detectors für combustibile gases, toxic gases or oxygen connectable (e.g. 8 AEM with 8 detectors each)
Power supply for detectors	24 Vdc (by regulated power supply)
Power consumption for detectors	maximum 3,5 VA / 150 mA (per detector)
Signal inputs	- standard 4-20 mA (by AEM), 2 or 3 wire, current base load ($R_{in} = 200 \Omega + 4300 / I(\text{mA})$) drift < 0.1% upper range value/month - RS485 (by LOOPM)
Signal processing	digital, 2 redundant 16 bit controllers with cycle time $t_z < 100 \text{ ms}$
Display and operation:	
Status information	- 7 LEDs per channel for operation, alarm and fault (on LED module) - system LEDs (on LCD-/Logo module)
Display	- LCD display for display of gas concentration and menu operation (on LCD module)
Operation	- 1 button per channel (on LED module) - 4 buttons for menu operation (on LCD module)
Housing:	
Types of housing	wall-mounted housing, 19"-rack with mounting plate or control panel with mounting plate
Dimensions and weight	depends on device configuration
Material (wall-mounted housing)	sheet steel (1.5 mm), powder-coated (RAL 7032)
Enclosure rating (wall-mounted housing)	IP 40 (optional IP 54)
Power supply:	
Supply voltage	230 Vac, 50 Hz or 24 Vdc (19,2 to 27,6 Vdc)
Power consumption	depends on system configuration and the amount and consumption of the connected detectors
Environmental conditions:	
Temperature	operation: 0 °C to +55 °C storage: -25 °C to +60 °C
Humidity	5% to 90% Rh
Pressure	80 to 120 Kpa
Vibration	10 to 55 Hz, maximum amplitude of 0,15 mm to avoid false alarms on the relay contacts the relay modules have to be installed vibration-free
Alarms, outputs and communication:	
Alarms	- 5 programmable Alarm levels (US, Alarm 1 -3, OS) and fault per channel - actual and average alarms configurable - AND, OR and VOTING function
Relay outputs	- up to 128 free-programmable charge over relay contacts (on 8 RBM / REM with 16 relay each) - resistive load: 250 Vac, 6 A

	4 system relays (on CM)
Signal outputs	4-20 mA or 0-10 v (by AAM); load for - 4-20 mA: maximum 450 Ω - 0-10 V: minimum 100 kΩ signal accuracy: < 2,5% upper range value
Datalogger	64 Mbit storage card (on CM)
Digital interfaces	- RS485, for communication with digital detectors (on AEM / LOOPM) - RS232, for configuration and visualization or calibration of digital detectors (on CM) - Centronics printer port
Certification:	
ATEX (Directive 94/9/EC)	X ₀₁₅₈ II (2)G, BVS 03 ATEX G 002 X Performance approval for explosion protection: - for combustible gases: according EN 60079-29-1 - for oxygen (inertisation): according EN 50104
Performance approval for oxygen	according EN 50104, PFG-Nr. 41300402 (Detection of oxygen deficiency and enrichment)
Performance approval for toxic gases	according EN 45544-1 / -2, PFG-Nr. 41300402
EMC (Directive 2004/108/EC)	according EN 50270 (type 1 and type 2)
Low Voltage (Directive 2006/95/EC)	according EN 61010-1
Functional Safety	SIL2 / SIL3 capable, according EN 61508 / EN 50402

Please see relevant data sheets for technical details of respective detectors.

7. Connection and configuration of the modules

7.1. Controller module (CM)

The CM, consisting of two PCBs, is fitted with relays for indication of service mode (make contact), single mode (make contact) as well as system failure (break contact). The relays are only provided for signals of up to 30 V DC, 0.1 A.

The rotary switch allows setting of the various functions for servicing (see chapter 3.4).

At the *External Reset* input all relevant relays and latching alarms can be reset with an external key connected.

In case no emergency power is supplied (24 V), a bridge connection between the 24 V inputs has to be made.

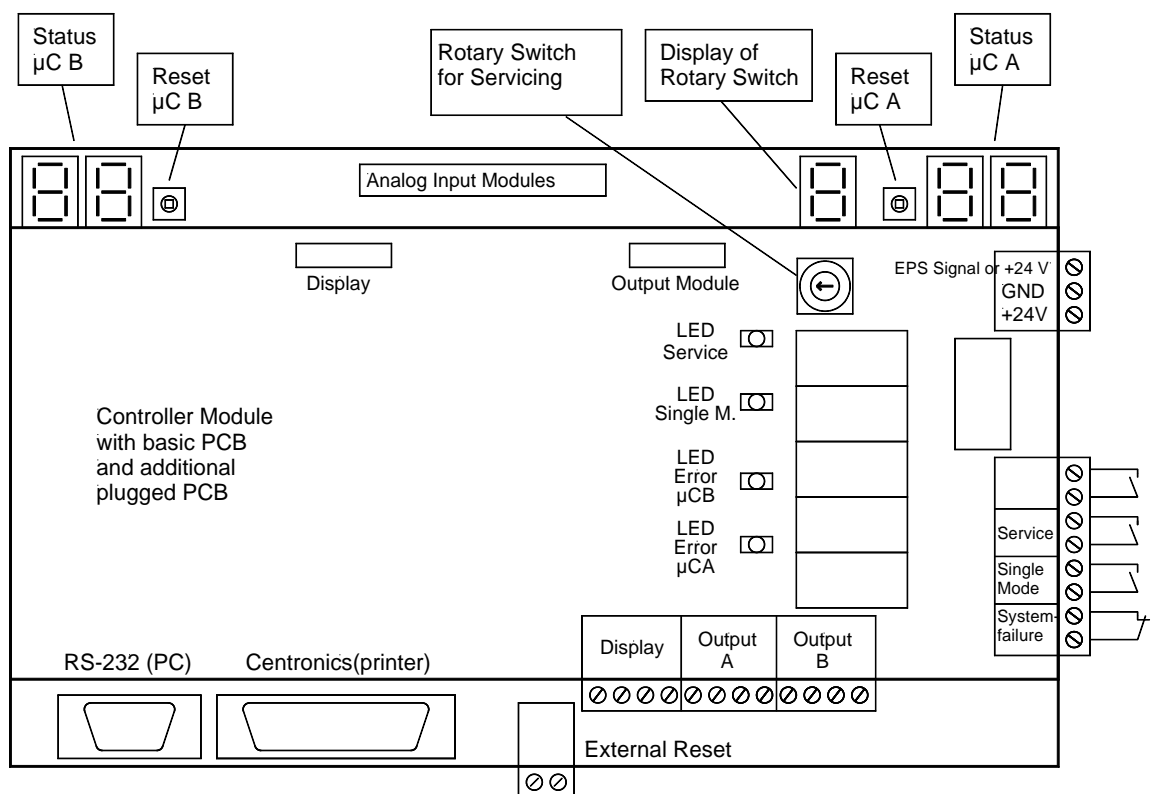

7.2. Analog input module (AEM)

Different addresses between 1 and 8 are to be allocated to the AEMs with help of the fitted rotary switch.

Five terminals each are available for all eight input channels:

- *24 V*: Power input requirement of the detector
- *GND*: Connection to ground (not required for 2-wire connections)
- *Sig.*: 4-20 mA signal from detector
- *A*: Line A of RS485 connection
- *B*: Line B of RS485 connection

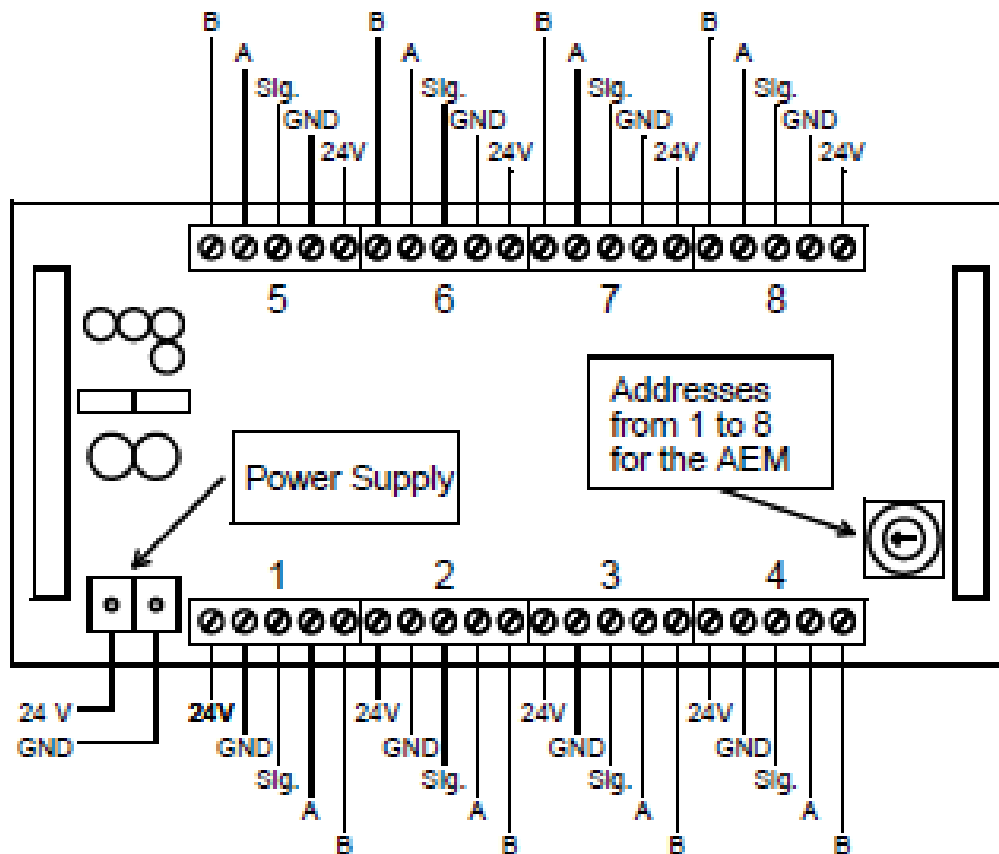

Module size: 160 x 90 x 50 mm

7.3. Analog input extension module (AEAM)

The AEAM needs to have the same address as the respective AEM.

The smoke detector has to be connected to the AEM, excepting the 24 V supply. The connection of the 24 V supply has to be done on the AEAM. Therefore the terminals 24 V of the AEM and AEAM are connected.

Each of the 8 channels has two connectors

- *24 V in*: Supply for the smoke detector (from AEM)
- *24 V out*: Supply for the smoke detector (to the detector)

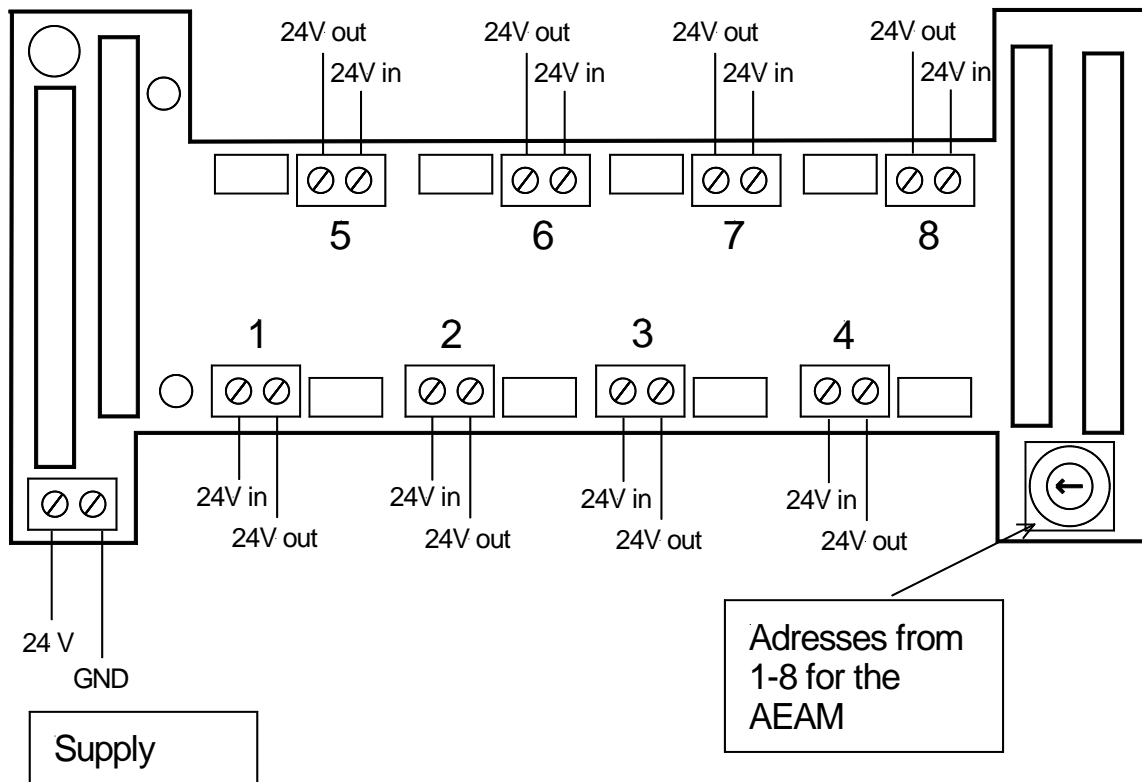

Module size: 160 x 70 x 50 mm

7.4. Basic relay module (RBM) and extension relay module (REM)

Different addresses between 1 and 8 have to be allocated to the relay modules with help of the fitted rotary switch.

The REM with relays 9 to 16 is plugged onto the RBM with relays 1 to 8. All 16 relays have a change-over contact (make contact, input, break contact).

Each relay has a pertaining jumper by which closed or open circuit operation can be selected (see 2.1.4).

- *upper position (R)*: closed circuit operation
- *lower position (A)*: open circuit operation

The last output module has to form a bus end for both signal buses with two jumpers (see figure).

- *left position*: end of bus
- *right position*: further output modules

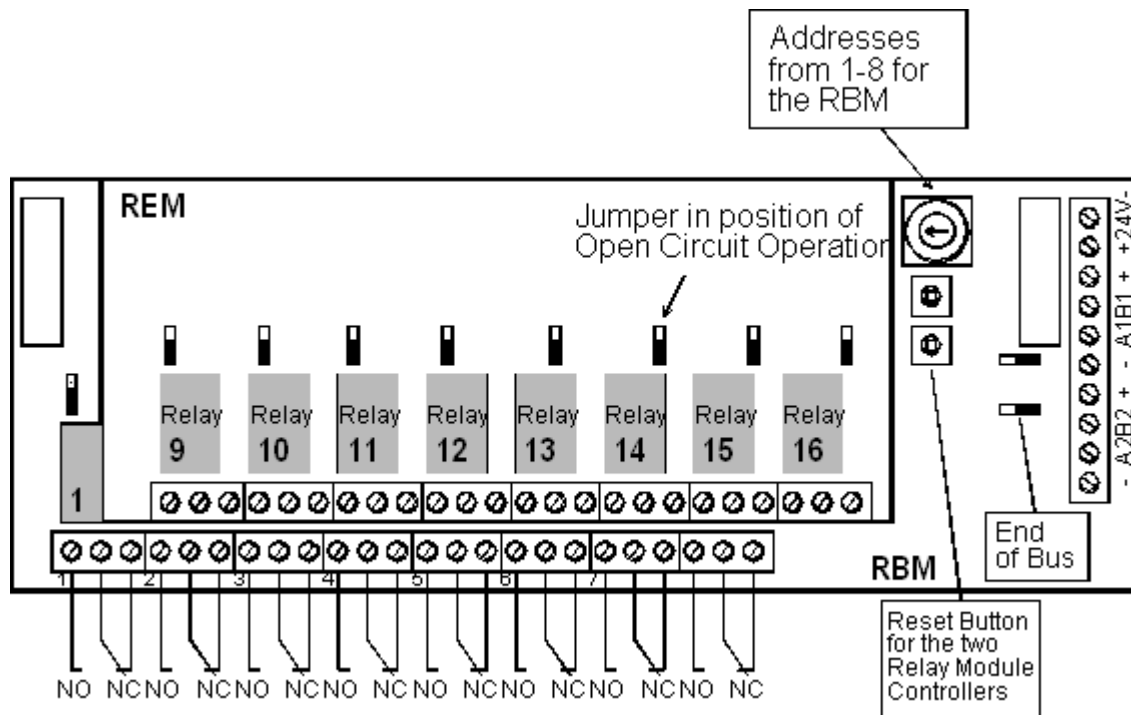

Module size: 190 x 90 x 75 mm

7.5. Loop module (LOOPM)

The address of the LOOPM has to be allocated with help of the fitted rotary switch.

Possible addresses for loop modules are 1, 3, 5 and 7. In case of a wrong address (even numbers), the loop module activates its LED *Fault*.

The last module of the output bus has to form a bus end with two jumpers. Contrary to the other modules on the output bus, the loop module has two jumpers J1 and J2 with only two contacts each.

- *J1 & J2 closed*: terminated output bus
- *J1 & J2 open*: non-terminated output bus

The jumper J3 is not used as its position does not affect the function of the module.

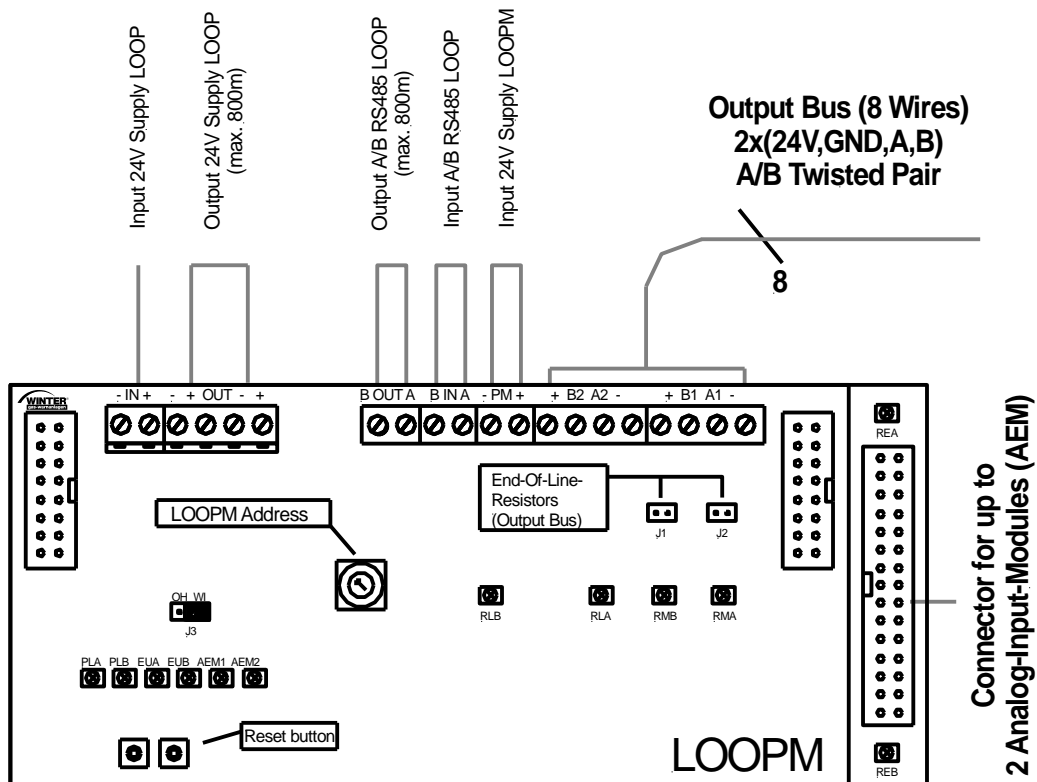

Module size: 167 x 90 x 85 mm

7.6. Analog output module (AAM)

Different addresses between 1 and 8 have to be allocated to the AAMs with the help of the fitted rotary switch.

Each output has a pertaining jumper by which 0-10 V or 4-20 mA can be selected.

- *left position:* 0–10 V
- *right position:* 4–20 mA

The last output module (whether it is a relay or analog output module) has to form a bus end for both signal buses (redundancy). This is done with the two jumpers on the upper right-hand side.

- *left position:* end of bus
- *right position:* further output modules

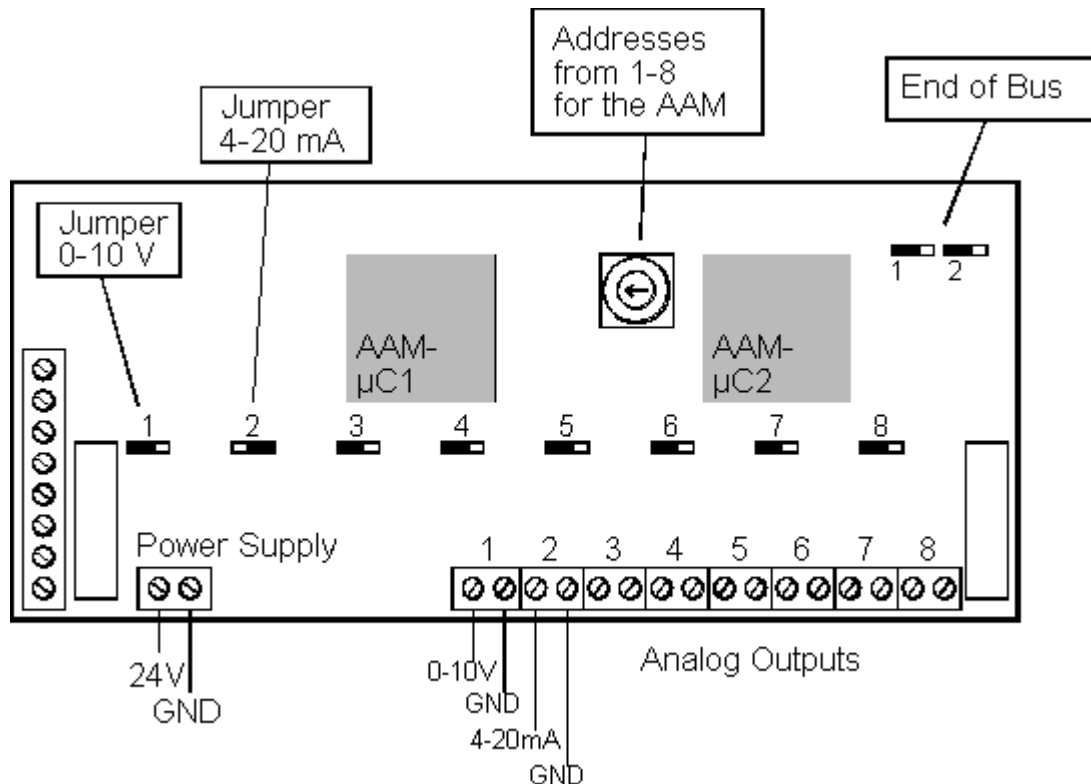

Module size: 160 x 90 x 50 mm

7.7. LCD module / LCD copy module

The LCD module with integrated data logger can accommodate a storing chip of 64 MB memorizing measured values, alarms and system events as well as 8-hour mean values.

All information stored can be shown on the LCD screen. The recorded values are shown on the LCD in form of a histogram.

If the LCD module/LCD copy module is the last module to be operated on the display bus, the bus will have to be terminated on the Module with the bus end jumper J1:

- *J1 open:* further display modules
- *J1 closed:* bus end

Background lighting and contrast can be set via potentiometers.

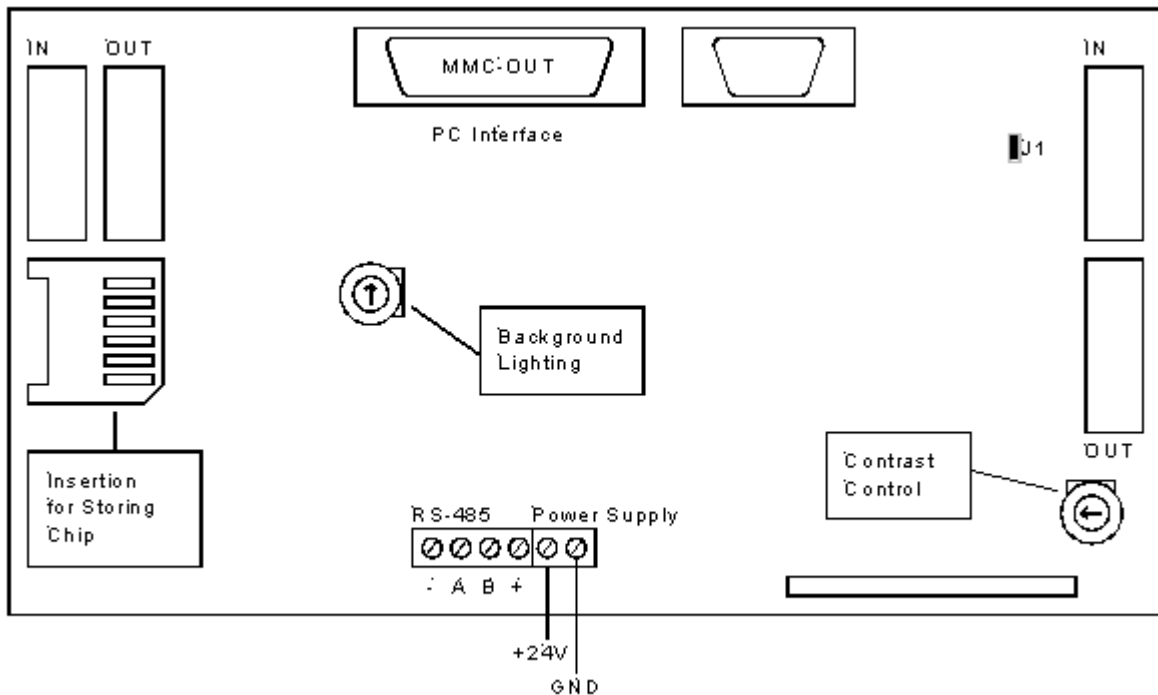

7.8. MIMIC Module

The address of the copied LED module has to be set with the address select switch at the MIMIC module. The switch is on the main PCB of the MIMIC module.

The maximum current of the OC outputs of the MIMIC module is 200mA.
For connection of external LED a 24V supply is needed.

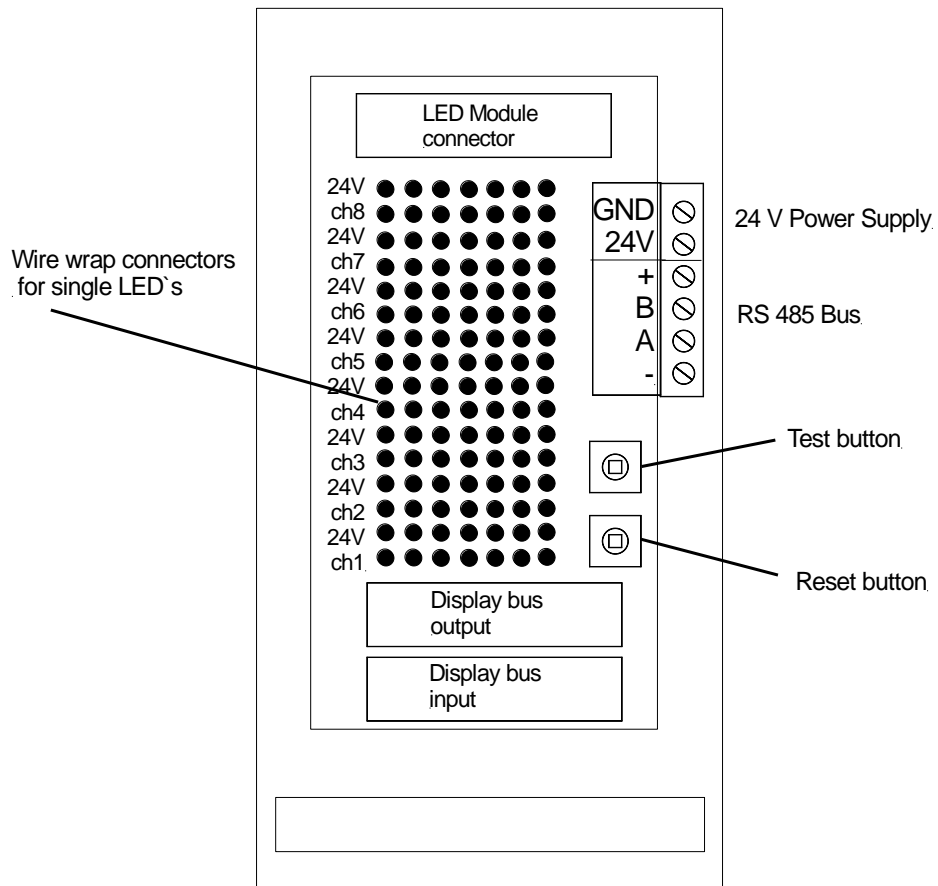

Module size: 160 x 71 x 128 mm

8. Connection and Installation

ATTENTION!

It is not allowed to install the WinPro[®] / MX62 in a hazardous areas.

8.1. Wiring

8.1.1. Mains supply

The electric installation for WinPro[®] / MX62 has to provide an isolator (e.g. an overload release) to guarantee secure disconnection from the mains supply. WinPro[®] / MX62 must not be installed in hazardous areas.

WinPro[®] / MX62 is designed for stationary installation to a mains supply of 230 V AC/50 Hz (also available for 24 V DC).

The unit complies with Protection Class I according to EN 60335 and has to be connected to a protective conductor (PE).

8.1.2. Connection of relays

A maximum of 128 relays (8 relay modules with up to 16 relays) with potential-free change-over contacts for 230 V/6 A resistive load can activate external devices or transmit information.

Selection of closed or open circuit operation is done by a jumper. Unshielded cables can be used for connection.

The relay modules can be connected through a flat or bus cable.

The maximum bus length is 800 m.

Installation of the relay modules must not be subject to any oscillation, the impact of which could cause short-term false signals at the relay outputs.

8.1.3. Connection of detectors

The gas detection system is designed for connection of up to 64 detectors (4-20 mA) by 2- or 3-wire technique.

Connecting of the detectors to the AEM is via shielded cable. Detectors with external input requirement must not be connected.

The sheath of the shielded line must be connected with the housing of WinPro[®] / MX62. In case the housing of the detector is made of metal, the sheath is also to be connected with this housing via the screwing.

The maximum cable length is determined by the detector to be connected (see respective data sheet) and must not be exceeded.

8.2. Installation of WinPro / MX62

ATTENTION!

Make sure power supply is cut off prior opening the unit.

8.2.1. Wall-mounted housing

The size of the wall-mounted housing depends on the number of modules. Safety systems should always be installed at a distance from any devices with high generic emission.

Attention is to be paid to free accessibility.

8.2.2. 19 inch rack

The distance between the 19 inch rack and the mounting plate must be less than three meters.

The sheath of the shielded line should be connected with the housing at the entry of the switchboard cabinet and on the mounting plate.

The relay modules and LED modules can be connected by a flat or bus cable. The maximum bus length is 800 m.

8.2.3. Control panel

The distance between CM and mounting plate must be less than three meters.

The sheath of the shielded line must be connected with the housing on the mounting plate.

The relay modules and LED modules can be connected by a flat or bus cable. The maximum bus length is 800 m.

9. Cut-out for control panel installation

The cut-out and bores apply to all three front panels (LED, LCD and Logo front panels).

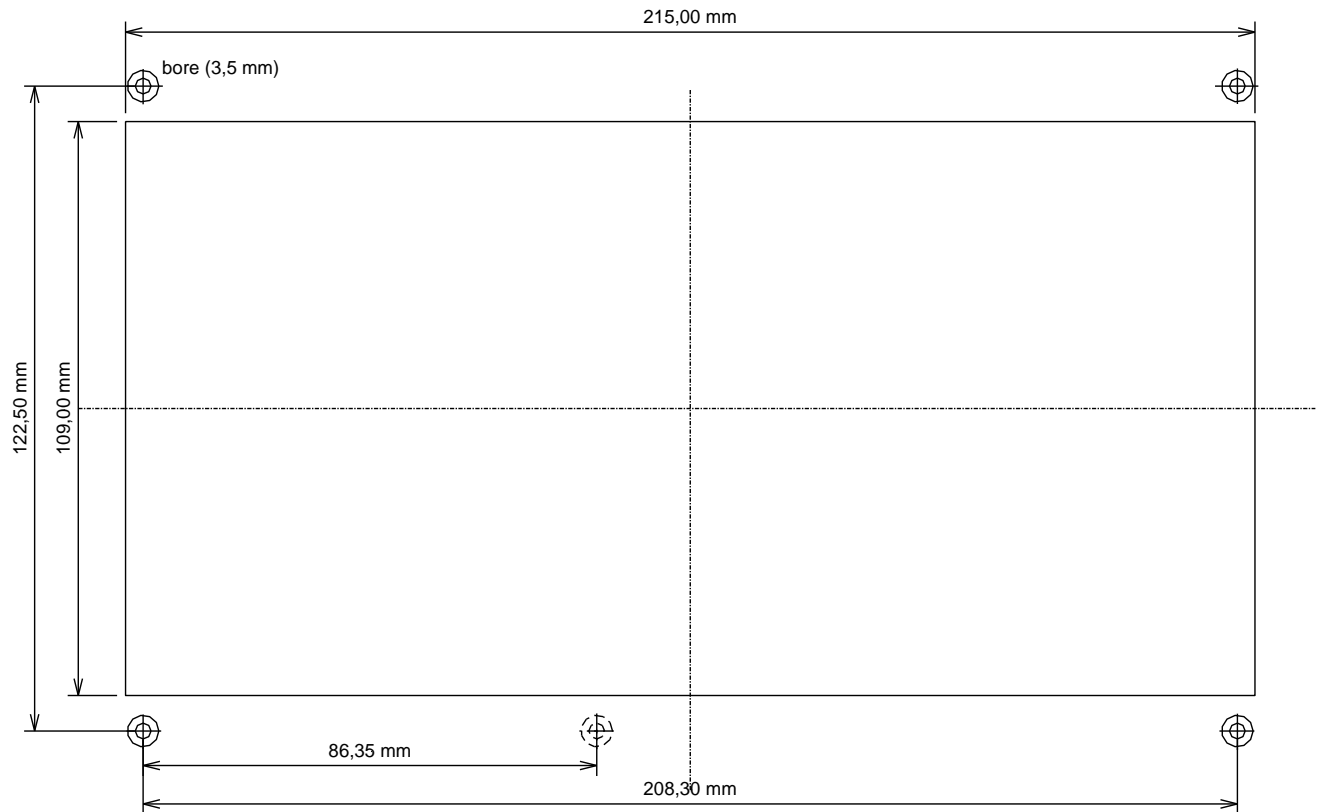

The front panels have a total size of 243 x 149 mm. The front panels project from the cut-out at top and bottom by 20 mm, left and right by 14 mm.

10. Accessories and spare parts

Part no.	Accessories
31550	Software <i>VisualPro</i> [®] for visualization of several linked <i>WinPro</i> [®] / MX62 units
31500	Software <i>ConfigPro</i> [®] for parameter settings of <i>WinPro</i> [®] / MX62
67040	Flashing luminous transparency 230 V AC
67160	Flashing alarm light 230 V AC
67010	Super tone horn 108 dB/m (A) 230 V AC
Spare parts	
31140	Analog input set (AES 8)
31150	Basic relay module (RBM 8)
31160	Extension relay module (REM 8)
31130	Analog output module (AAM 8)
31445	LCD copy module set for 19 inch rack

Please ask OLDHAM or your local distributor for further accessories and spare parts.

11. Certifications

11.1. CE accreditation

WinPro[®] / MX62 complies with the basic safety requirements of the following European directives (see also chapter 12).

ATEX Directive (94/9/EC):

The gas detection system is approved for measurements in explosive areas for safety functions using certified detectors as TBGW EX. The corresponding EC type examination certificate is:

BVS 03 ATEX G 002 X

For details, certified applications and special conditions of safe use please refer to chapters 11.2 and 11.3.

EMC Directive (2004/108/EC):

The unit has passed EMC testing according to EN 50270 and can be installed in domestic and industrial areas with regards to generic emission and immunity.

Low Voltage Directive (2006/95/EC):

The system is in compliance with EN 61010-1 Part 1, Safety regulations for electric measuring, control and laboratory equipment.

11.2. Performance approvals

WinPro[®] / MX62 is approved by DEKRA EXAM according to EN 60079-29-1 (combustible gases), EN 50104 (oxygen), EN 45544-1 / -2 (toxic gases) and EN 50271 (digital technique).

The corresponding performance approval certificates are:

BVS 03 ATEX G 002 X and PFG 41300402

Performance approval include the following detection ranges:

- 0-20% LEL
- 0-100% LEL
- 0-100 % vol. CH₄
- 0-100 % vol. CO₂
- 0-10 % vol. O₂
- 21-0 % vol. O₂

- 0-25 % vol. O₂
- 0-1000 ppm NH₃
- 0-300 ppm CO; MBU/NA: 1 1.2/2.4 ppm CO
- 0-500 ppm CO; MBU/NA: 2/4 ppm CO
- 0-3000 ppm CO₂; MBU/NA: 20/25 ppm CO₂
- 0-5 % vol. CO₂; MBU/NA: 0.02/0.04 % vol. CO₂
- 0-50 ppm H₂S; MBU/NA: 0.2/0.4 ppm H₂S
- 0-100 ppm H₂S; MBU/NA: 0.4/0.8 ppm H₂S

The performance approval does not include the following functions described in this operation manual:

- Data logger of LCD module (see chapter 2.1.7)
- Calibration of 4-20 mA input of standard detectors (see chapters 3.4.3 and 5.1.2)
- Calibration and adjustment of WINTER digital detectors (see chapter 5.1.3)
- LCD copy module (see chapter 7.7)
- *ADVANCED* relay configuration (see manual *ConfigPro*)
- MIMIC module (see chapter 7.8)
- Analog input extension module AEAM (see chapter 2.1.9)
- Profibus module (PBM)
- Functional safety (see chapter 14)

ATTENTION!

The performance approval will only be valid if the gas detection system is used together with detectors having the same approval.

11.3. Special conditions for safe use

- The control unit has to be operated in a way that one relay output must be configured as collective relay for all channel malfunctions.
- The outputs for measured values are to be operated as current outputs.
- Installation of the relay modules must not be subject to any oscillation, the impact of which could cause short-term false signals at the relay outputs.

¹ MBU/NA: Minimum end scale value and zero drift according to EN 45544. When connecting a transmitter, its respective values have to be observed. In case of combination, the higher value is valid.

- Indication on the LCD display must not be used for any safety control purposes.
- Alarm 3 must be configured to be latching when measuring combustible gases or oxygen.
- This EC examination certificate includes the use of LOOPM in combination with the detector TBGW EX (see BVS 03 ATEX E 101). The operation of a Loop Module with transmitters of different type via the digital interface has to be certified by a separate supplement to the EC-type examination certificate.
- If a remote sensor with internal relays in combination with LOOPM is used, it has to be ensured that a failure of data transmission to the remote sensor is unambiguously signalled. For this purpose a relay output of a relay module has to be configured in a way that a failure of data transmission and the subsequent loss of function of the transmitter relay are signalled. If more than one transmitter with internal relays is connected, this signal may be configured as a common signal.
- When a communication fault with digital connected detectors occurs, a fault signal will be given inbetween 30 s after communication breakdown.
- When connecting detectors with a 4-20 mA interface, the interface features below and above 20 mA has to be considered.
- The evaluation of function safety for the control device is not part of the EC type examination certificate.
- Please note that when employing the gas detection unit at very low concentrations of the target gas, measurement uncertainty is higher than 50% for the ranges of 0-5 % vol. CO₂ and 0-100 ppm H₂S.

12. EU declaration of conformity



DECLARATION UE DE CONFORMITE EU Declaration of Conformity



La société **Oldham S.A.S.**, ZI Est 62000 Arras France, atteste que la
Oldham S.A.S. company, ZI Est 62000 Arras France, declares that the

centrale de mesure MX62 ***MX62 Controller***

est conforme aux exigences des Directives Européennes suivantes:
complies with the requirements of the following European Directives:

I) Directive Européenne ATEX 2014/34/UE du 26/02/14: Atmosphères Explosives

The European Directive ATEX 2014/34/EU dated from 26/02/14: Explosive Atmospheres

Normes appliquées :
(Applied Standards)

EN 60079-29-1:07 Exigences d'aptitude à la fonction des
détecteurs de gaz inflammables
Performance requirements of detectors for flammable gases
EN 50104:10 Exigences d'aptitude à la fonction des
détecteurs d'oxygène
Performance requirements of detectors for oxygen
EN 50271:01 Appareils de détection de gaz utilisant un
logiciel et/ou des technologies numériques
*Apparatus for the detection of gases using software and/or
digital technologies*

Catégorie et marquage (*Category and Marking*):

 **II (1)G (2)G**

Attestation CE de Type du matériel:
EC type examination certificate

BVS 07 ATEX G 001 X

Délivré par l'Organisme Notifié numéro 0158:
Issued by the Notified Body No. 0158

DEKRA EXAM GmbH, 44809 Bochum
Dinnendahlstr.9, Germany

Notification Assurance Qualité de Production:
Notification of the Production QA

INERIS 00 ATEX Q403

Délivré par l'Organisme Notifié numéro 0080:
Issued by the Notified Body No. 0080

INERIS, Parc Alata
60550 Verneuil-en-Halatte, France

II) Directive Européenne CEM 2014/30/UE du 26/02/14: Compatibilité Electromagnétique

The European Directive EMC 2014/30/UE dated from 26/02/14: Electromagnetic Compatibility

Normes harmonisées appliquées: **EN 50270:06** for type 1&2
Harmonised applied Standards

CEM-Appareils de détection de gaz
EMC-Apparatus for the detection of gases

Atmosphères des lieux de travail (Workplace Atmospheres)

Normes appliquées:
(Applied Standards)

EN 45544-1:99 / EN 45544-2:99 / EN 45544-3:99
Exigences d'aptitude à la fonction des détecteurs de gaz toxiques
(Performance requirements of detectors for toxic gases)

Sécurité de Fonctionnement (Safety Instrumented System)

Normes appliquées:
(Applied Standards)

IEC 61508-1:10 Exigences générales (*General requirements*)
IEC 61508-2:10 Exigences pour les systèmes E/E/EP relatifs à la sécurité
(requirements for E/E/PE safety-related systems)

Niveau d'intégrité de sécurité **SIL 3/ SIL 2**
(Safety Integrity Level)

Certificat (*certificate*) BVS Pb 09/11 X par (*by*)
DEKRA EXAM GmbH

Arras, le 20/04/2016 (April 20th, 2016)

Michel Spellemaeker



Oldham S.A.S.

Z.I. EST - B.P. 20417

62027 ARRAS Cedex - FRANCE

www.oldhamgas.com



Global Director of Product Management

UE_atex_MX62_revA

13. Translation of data logger messages

In the foreign language versions of the operation manual for *WinPro* this chapter contains the translations for the data logger messages which are in English language originally.

14. Requirements for Functional Safety (SIL)

This chapter describes the requirements for the installation of the gas detection system WinPro[®] / MX62 in safety related applications.

14.1. Basics

Functional safety considers only aspects to avoid or control the disturbance of the normal system functionality.

The normal operation is not part of this consideration. For normal operation, please refer to other chapters of this manual and the manuals of the connected detectors.

14.2. Operation in safety related systems according EN 61508

The WinPro[®] / MX62 is designed for operation in safety related applications with requirements for functional safety including SIL 3 capability according EN 61508. Basis for the evaluation of WinPro[®] / MX62 is the EN 50402 for functional safety of fixed gas detection systems.

Following is given a planning aid for the integration of WinPro[®] / MX62 in a safety related system:

- Definition of safety related functions
- Definition of proof tests (T1) for safety related functions
- Requirements for configuration of WinPro[®] / MX62
- Failure rates of WinPro[®] / MX62 (PFD values); for use in failure rate calculations of a safety related system according EN 61508
- Directions for operation in safety related applications

14.3. Definition of safety functions

The gas detection system WinPro[®] / MX62 with its safety related functions is only part of a safety related system.

The safety related function of WinPro[®] / MX62 starts at the signal inputs of the analog input module (AEM) and ends at the relay outputs of the gas detection system (RBM/REM). The signal processing chain consists of analog input module, controller module (CM), relay module and the communication lines between these modules.

The WinPro[®] / MX62 provides different safety related und non-safety related outputs:

Safety related outputs (relays):

- System failure relay on CM
- Relay outputs on the relay modules

Non-safety related outputs:

- Visual indications (LED-, LCD- and logo module)
- Analog outputs (AAM)
- Relays for indication of emergency operation and service mode

The requirements for the safety related functions of WinPro[®] / MX62 are result of the safety plan of a safety related application. In addition existing legal or official conditions have to be considered.

Example:

A relay output to control a visual alarm indication has in general lower safety requirements then a relay output for an emergency shut down of a manufacturing plant.

14.4. Configuration of WinPro / MX62

The EN 50402 requires a SIL capability for each safety related function of a gas detection system. The SIL capabilities have to correspond with the safety integrity level (SIL) of EN 61508.

The signal processing of WinPro[®] / MX62 is designed following the requirements of SIL 3 capability. The signal processing and the communication between the signal inputs on the analog input modules via controller module to the relay outputs are completely redundant.

The visual indications (e.g. LED and LCD module) are not part of the safety chain. They are not considered in the SIL evaluations.

Applications with SIL 2 capability:

For each detection point one (1) detector is needed and for the safety related function one (1) relay is used.

The signal processing inside WinPro[®] / MX62 is redundant for increased availability.

Applications with SIL 3 capability:

For each detection point two (2) redundant detectors are needed and for the safety related function two (2) independent relays have to be used.

The signal processing inside WinPro[®] / MX62 is completely redundant and SIL 3 capable.

14.4.1. Requirements for SIL 2 configurations

- Connection of one (1) SIL 2 capable detector on an input of the AEM.

- If only SIL 1 capable detectors are available, two (2) redundant detectors for each detection point are needed.
- Two redundant detectors, that are assigned to the same detection point, have to be connected in one detection group by software *ConfigPro* (If these detectors are not connected to one detection group, each detector has to release the safety related function independently. It is not allowed to connect the alarm events of these channels with an AND or VOTING logic. Both channels have to be configured identically, e.g. with same alarm values).
- For SIL 2 capability only one (1) relay output for each detection point or safety related function is needed.
- If two (2) SIL 1 capable detectors are used, the alarm events of these detectors have to be connected with an OR logic on the corresponding relay output to allow each detector to release the safety related function independently.
- A system failure of WinPro is indicated by redundant system failure relays on the controller module. These relays have a hardware based OR logic and have to be used as static current relays. The system failure relays have to be integrated in the safety plan of the application.

14.4.2. Requirements for SIL 3 configurations

- If SIL 2 capable detectors are used, two (2) redundant detectors for each detection point are needed. Two redundant detectors, that are assigned to the same detection point, have to be connected in one detection group by software *ConfigPro* (If these detectors are not connected in one detection group, each detector has to release the safety related function independently. It is not allowed to connect the alarm events of these channels with an AND or VOTING logic. Both channels have to be configured identically, e.g. with same alarm values).
- If SIL 1 capable detectors are used, three (3) redundant detectors for each detection point are needed. In addition the SIL 3 capability has to be proved by calculation of the failure rates for 1 of 3 (1oo3).
- If two (2) SIL 2 capable detectors are used for one detection point two (2) relay outputs have to be configured for this detection point in a way that each detector will release the safety related function independently. All relays as part of one safety related function have to be configured with the same switch conditions. For the connection following configurations are allowed:
 - a) Each detector is assigned to one specific relay. The switching of one relay releases the safety related function.

- b) Both detectors are connected by OR logic to one relay output. A second relay has to be configured identically. The switching of one relay releases the safety related function.
- A system failure of WinPro is indicated by redundant system failure relays on the controller module (CM). These relays have a hardware based OR logic and have to be used as static current relays. The system failure relays have to be integrated in the safety plan of the application.

14.4.3. Remarks for relay configuration

By safety technical considerations it is recommended to configure the relays as static current relays. A disadvantage of this configuration is that it is not possible to distinguish between an alarm event and a power failure of the WinPro.

As it is mandatory to have the system failure relays configured as static current relays and these relays have to be integrated in the safety plan of the application it can be disclaimed to use the alarm relays as static current relays also.

For the connection of redundant relays the opening contacts have to be set parallel and the closing contacts in series.

14.4.4. Recommendations for increased availability

Additional to the safety requirements of the standards EN 50402 and EN 61508 following recommendations are given to increase the availability of the detection system.

As a breakdown of WinPro will lead to a safety state (system failure), the safety of the complete system is given. The following recommendations can reduce the probability of a system failure additionally:

- The use of an uninterruptible power supply can lead to a significant higher availability of the detection system.
- If redundant detectors are connected to different analog input modules (AEM), the breakdown of one AEM will not lead to a safety risk. The second detector is still available.
- If remote relay modules are connected with separate cable ducts between controller module and relay module, by mechanical damage of one cable the relays will be still available. Additional it is recommended to lay the cables on different routes.

14.5. Failure rates for WinPro / MX62 (PFD value)

For integration in a safety related system, additional to the SIL capability a value for probability of failures in alarm state is needed. This value is named PFD (Probability of Failure on Demand).

The maximum PFD value is defined for a complete safety chain. For SIL 2 is $\text{PFD} < 10^{-2}$ and for SIL 3 is $\text{PFD} < 10^{-3}$.

There is a general agreement that 35% of the maximum PFD value is assigned to the detector, 15% to the control unit (WinPro) and 50% to the actor part of the safety chain. This leads to following PFD values for WinPro:

$$\text{SIL 2} < 1.5 \times 10^{-3}$$

$$\text{SIL 3} < 1.5 \times 10^{-4}$$

WinPro[®] / MX62 is a partly redundant system with redundant and non-redundant functions. These functions have been validated separately in an FMEDA study. The following PFD values have been calculated from it.

For the calculation of PFD an average repair time (MTTR) of 72 hours is assumed. The PFD is calculated for proof test intervals (T1) of one, two and three years.

- PFD value for a simple safety chain with an input of one connected detector and an output of one assigned relay contact:

- a) With a proof test interval of one year:

$$\text{PFD} = 5.24 \times 10^{-4}$$

- b) With a proof test interval of two years:

$$\text{PFD} = 1.03 \times 10^{-3}$$

- c) With a proof test interval of three years:

$$\text{PFD} = 1.54 \times 10^{-3}$$

- PFD value for a fully redundant safety chain with an input of two redundant detectors for one detection point and an output of two assigned separate relay contacts:

- a) With a proof test interval of one year:

$$\text{PFD} = 2.95 \times 10^{-5}$$

b) With a proof test interval of two years:

$$\text{PFD} = 5.88 \times 10^{-5}$$

c) With a proof test interval of three years:

$$\text{PFD} = 8.89 \times 10^{-5}$$

The calculated values are based on the assumption that the specified intervals for service and maintenance of WinPro[®] / MX62 and for the connected detectors are kept. These service intervals have to be defined before operation of the detection system.

14.6. Directions for use in safety related applications

- For safety related applications it has to be observed that WinPro[®] / MX62 is not exposed to vibrations.
- All remote modules and the connection lines that are part of a safety related function have to be protected against mechanical damage and EMC influences.
- The relay basis module (RBM) has to be connected via bus cable. This is also mandatory when installed inside the WinPro[®] / MX62 cabinet.
- All channel failures have to be signaled and evaluated as collective fault by minimum one (1) relay contact. Short circuit and cable break in the lines to the connected detectors have to be detected as failure. Corresponding maintenance activities have to be carried out in an appropriate period.
- Special conditions of detectors that are stated actively on the signal output, e.g. $\leq 2 \text{ mA}$, under scale and over scale have to be detected and evaluated by WinPro[®]. For detectors of Oldham this is ensured automatically.
- It is not allowed to use ADVANCED relay configurations for safety related functions.

Proof test:

The complete safety related functionality of WinPro / MX62 has to be tested regularly in intervals of the proof test. Therefore see also Chapter 5 - Commissioning and maintenance.

The data processing of WinPro is based on the signal inputs of the connected detectors. The functionality of WinPro is tested by applying test gas on the detectors or by connecting of electrical signal transducer (mA-Geber) to the WinPro.

All relays as part of a safety related function and the system failure relays have to be tested on release.

The event log has to be read out and evaluated.

The proof test interval (T1) has to be defined by the operator. In chapter 14.5 are given the PFD values for intervals of one (1) year, two (2) years and three (3) years.

In Germany the proof test has to be done minimum once a year. The proof test corresponds to the system control of “Merkblatt T 23” of BG RCI and to the Betriebssicherheitsverordnung (BetrSichV). This is a recommendation for Europe.



EUROPEAN PLANT AND OFFICES

Z.I.Est – rue Orfila CS 20417 – 62027 Arras Cedex FRANCE
Tél: +33 (0)3 21 60 80 80 – Fax: +33 (0)3 21 60 80 00
Website: <http://www.oldhamgas.com>

AMERICAS
Tel: +1 713-559-9280
Fax: +1 281-292-2860
americas@oldhamgas.com

ASIA PACIFIC
Tel: +86-21-3127-6373
Fax: +86-21-3127-6365
sales@oldhamgas.com

EUROPE
Tel: +33-321-608-080
Fax: +33-321-608-000
info@oldhamgas.com